



INVITATION FOR BID

Construction

B24-022AL

Date issued: January 26, 2024

LADDERS TRAIL CONSTRUCTION IN NORTH CHEYENNE CANON PARK

THE CITY OF COLORADO SPRINGS

The City of Colorado Springs hereby solicits Fixed Unit Price (FUP) Bids, as detailed in this Invitation For Bids (IFB), for the construction of Ladders Trail in North Cheyenne Canon Park.

This IFB is posted to BidNet Direct and the City of Colorado Springs' Procurement Services Website. It is available for all vendors free of charge, following free registration, at the BidNet Direct website.

SUBMITTALS FOR THIS PROJECT WILL ONLY BE ACCEPTED ON THE BIDNET DIRECT PLATFORM.

Please login to the following website to register (Free Registration) to submit a bid for this project. All required documents will be uploaded to the BidNet website. The City of Colorado Springs belongs to BidNet's Rocky Mountain e-Purchasing Group within BidNet.

<https://www.bidnetdirect.com/>

BIDNET Direct Support

800-835-4603

Estimated Project Magnitude: \$125,000 - \$175,000

SECTION I – BID INFORMATION

1.0 BID INFORMATION

Section I provides general information to potential Bidders, such as bid submission instructions and other similar administrative elements. This Invitation for Bid (IFB) is available on BidNet (www.bidnetdirect.com). All addenda or amendments shall be issued through BidNet and may not be available through any other source.

1.1 SPECIAL TERMS

Please note the following definitions of terms as used herein:

The term “City” means the City of Colorado Springs.

The term “Contractor” or “Consultant” means the Bidder whose offer is accepted and is awarded the contract to provide the products or services specified in the IFB.

The term “Offer” or “Bid” means a bid submitted in response to this IFB.

The term “Offeror” or “Bidder” means the person, firm, or corporation that submits a formal bid or offer and that may or may not be successful in being awarded the contract.

The term “Project” refers to the Ladders Trail in North Cheyenne Canon Park Construction Project.

The term “Invitation for Bid” or “IFB” means this solicitation of formal, competitive, sealed bids from prospective bidders in which the intent is to award a contract to the resultant lowest responsible and responsive bidder.

1.2 BID ISSUE DATE

Invitation for Bid (IFB) Number B24-022AL is being issued and posted on www.bidnetdirect.com on January 26, 2024.

1.3 SUBMISSION OF BIDS

- A. Bids are to be submitted electronically on BidNet Direct (www.bidnetdirect.com). Please review the submission requirements **well in advance** of submission date and time, and allow for ample time to upload each required document. It is recommended that Offerors begin the submission process at least one (1) day in advance of the proposal deadline.

Offerors are solely responsible to ensure all required bid documents are uploaded and submitted correctly, and that a **confirmation number** is obtained upon successful submission. Customer support for BidNet Direct may be reached at (800) 835-4603.

- B. Bids shall be received on or before: Wednesday, February 21, 2024 no later than 2:00 PM MST. A public opening will be held via Microsoft Teams at that time. Web access and dial in information is below:

Join on your computer, mobile app or room device

[Click here to join the meeting](#)

Meeting ID: 225 625 906 588

Passcode: NTOZvi

[Download Teams](#) | [Join on the web](#)

Or call in (audio only)

[+1 720-617-3426,,301340612#](#) United States, Denver

Phone Conference ID: 301 340 612#

C. Bid bond is required if total bid exceeds \$50,000.00. (Also see 1.22)

D. The cost of Bid preparation is not a reimbursable cost. Bid preparation shall be at the Bidder's sole expense and is the Bidder's total and sole responsibility.

1.4 PRE-BID CONFERENCE

A pre-bid meeting will be held via Microsoft Teams at 10:00AM MST Thursday, February 1, 2024. This meeting is highly encouraged but not mandatory.

Dial in information is:

Join on your computer, mobile app or room device

[Click here to join the meeting](#)

Meeting ID: 258 563 788 172

Passcode: dLhQpn

[Download Teams](#) | [Join on the web](#)

Or call in (audio only)

[+1 720-617-3426,,554686931#](#) United States, Denver

Phone Conference ID: 554 686 931#

1.5 LATE BIDS/LATE MODIFICATIONS OF BIDS

Bids, withdrawals or modifications of Bids received after the time set for opening, as designated in 1.3 above, are considered "late bids", and will not be accepted by the City, except as provided for in the City of Colorado Springs Procurement Rules and Regulations and approved by the Procurement Services Manager. Bidders are solely responsible for ensuring their bids arrive on time and to the place specified in this Invitation for Bid.

1.6 MISTAKES IN BIDS - CONFIRMATION OF BID

If it appears from a review of a Bid that a mistake has been made, the Bidder may be requested to confirm its Bid in writing. Situations in which the confirmation may be requested include obvious, apparent errors on the face of a Bid or a Bid unreasonably lower than the other Bids submitted. All mistakes in Bids will be handled in accordance with the City of Colorado Springs Procurement Rules and Regulations.

1.7 PROCUREMENT RULES AND REGULATIONS

All formal IFBs advertised by the City of Colorado Springs are solicited in accordance with the City's Procurement Rules and Regulations. The City's Procurement Rules and Regulations can be reviewed and/or downloaded from the City's Procurement Services Division website at www.coloradosprings.gov. Any discrepancies or conflicting statements, decisions regarding bidding irregularities, or clarifications regarding clauses or specifications will be rectified utilizing the City's Procurement Rules and Regulations, when applicable. It is the Bidder's responsibility to advise the Contracts Specialist listed in this IFB of any perceived discrepancies, conflicting statements, or problems with clauses or specifications prior to the Bid opening date and time.

1.8 MINOR INFORMALITIES/IRREGULARITIES IN BIDS

- A. A minor informality or irregularity is one that is merely a matter of form and not of substance. It also pertains to some immaterial defect in a Bid or variation of a Bid from the exact requirements of the invitation that can be corrected or waived without being prejudicial to other Bidders. The defect or variation is considered immaterial when the effect on price, quantity, quality, or delivery is negligible when contrasted with the total cost or scope of the goods and/or services being acquired.
- B. If the City Procurement Services Division determines that a Bid submitted contains a minor informality or irregularity, then the Procurement Services Manager shall either give the Bidder an opportunity to cure any deficiency resulting from the minor informality or irregularity or waive the deficiency, whichever is to the advantage of the City. In no event will the Bidder be allowed to change the Bid amount. Examples of minor informalities or irregularities include but are not limited to the following:
 - 1. Bidder fails to sign the Bid, but only if the unsigned Bid is accompanied by other material evidence, which indicates the Bidder's intention to be bound by the unsigned Bid (such as Bid security, or signed cover letter which references the Bid Number and amount of Bid).
 - 2. Bidder fails to acknowledge an Amendment, although this may be considered a minor informality only if the Amendment, which was not acknowledged, involves only a matter of form or has either no effect or merely a negligible effect on price, quantity, quality, or delivery of the item or services bid upon.

1.9 REJECTION OF BIDS

The Procurement Services Manager has the authority to reject any Bid based on, but not limited to, the following:

- A. Any Bid that fails to conform to the essential requirements of the Invitation for Bids shall be rejected.
- B. Any Bid that does not conform to the applicable specifications shall be rejected unless the IFB authorizes the submission of alternate bids and the items or services offered as alternates meet the requirements specified in the IFB.
- C. A Bid that fails to conform to the specified delivery schedule.
- D. A Bid shall be rejected when the Bidder imposes conditions that would modify requirements of the IFB or limit the Bidder's liability to the City, since to allow the Bidder to impose such conditions would be prejudicial to other Bidders.

For example, Bids shall be rejected in which the Bidder:

1. Protects against future changes in conditions, such as increased costs, if total possible costs to the City cannot be determined. This includes failure to completely fill out required bid schedule.
 2. Fails to state a price and indicates that price shall be "price in effect at time delivery".
 3. States a price but qualifies it as being subject to "price in effect at time of delivery".
 4. Takes exceptions to the IFB terms and conditions.
 5. Inserts the Bidder's terms and conditions.
 6. Limits the rights of the City under any Contract/Invitation for Bid clause.
- E. Any Bid in which the price is considered to be unreasonable or is over budget.
- F. Any Bid if the prices are determined to be unbalanced.
- G. Bids received from any person or contractor that is suspended, debarred, proposed for debarment, or under investigation for fraud, including failure to pay federal, state, local or city taxes.
- H. When a bid guarantee is required and the bidder fails to furnish the guarantee in accordance with the requirements of the IFB.
- I. Low Bids received from bidders who are determined to be non-responsible in accordance with the City's Procurement Rules and Regulations.
- J. Any Bid that was prepared and submitted by a vendor who has been determined by the Procurement Services Manager to have an unfair advantage over other Bidders. Examples of an unfair advantage include, but are not limited to, the following:
1. A previous or prior employee who in the last six (6) months was directly involved in the design or specification preparation of the competed procurement.
 2. A vendor who was directly involved in design or specification preparation of the competed project either for pay or voluntarily.

1.10 ESTIMATED QUANTITIES

If the Bid Form (Schedule A) herein contains estimated quantities, this provision is applicable. The quantities listed for each of the items in the Bid Form are only estimated quantities. Contractors are required to bid a firm unit price for each item specified. The actual quantities ordered may fluctuate up or down. The unit prices proposed by each Bidder will remain firm and will not be re-negotiated if the estimated quantities are not met or are exceeded. This clause will take precedence over any/all other estimated quantity clauses that conflict with this clause.

For bidding purposes, if there is a conflict between the extended total of an item and the unit price, the unit price shall prevail and be considered as the amount of the Bid. All unit prices shall include all necessary overhead and profit. Items not listed in the Bid Form such as overhead, profit, mobilization, de-mobilization, bonding, etc. shall be distributed throughout the Bidder's Unit Prices for the items listed on the Bid Form.

1.11 NUMBER OF COPIES

Bidders shall submit one electronic copy of each required document on the BidNet Direct Procurement Platform (www.bidnetdirect.com). Upon submission, all Bid documents shall become and remain the property of the City.

1.12 IDENTIFICATION OF BID

Bids must be submitted to the BidNet Direct Procurement Platform (www.bidnetdirect.com). The solicitation number and Offeror name must be clearly marked within the Bid.

Bid No.: B24-022AL

Due Date and Time: Wednesday, February 21, 2024 no later than 2:00 PM MST.

1.13 SALES TAX

The successful Offeror, if awarded a contract, shall apply to the Colorado Department of Revenue for a tax-exempt certificate for this project. The certificate does not apply to City of Colorado Springs Sales and Use Tax which shall be applicable and should be included in all bids and proposals. The tax-exempt project number and the exemption certificate only apply to County, PPRTA (Pikes Peak Rural Transportation Authority), and State taxes when purchasing construction and building materials **to be incorporated into this project**.

Furthermore, the exemption **does not** include or apply to the purchase or rental of equipment, supplies or materials that **do not become a part of the completed project or structure**. In these instances, the purchase or rental is subject to full taxation at the current taxation rate.

The Offeror and all subcontractors shall include in their Offer City of Colorado Springs Sales and Use Tax on the work covered by the offer, and all other applicable taxes. Any increase in applicable sales or use tax occurring after the contract has been let shall be borne by the contractor and not passed through to the City.

Forms and instructions can be downloaded at the City of Colorado Springs Website:<https://coloradosprings.gov/sales-tax/page/additional-sales-tax-forms?mlid=30771>. Questions can be directed to the City Sales Tax Division at (719) 385-5903 or Construction_SalesTax@ColoradoSprings.gov.

Our Registration Numbers are as follows:

City of Colorado Springs

Federal I.D.: 84-6000573

Federal Excise: A-138557

State Sales Tax: 98-03479

1.14 PREPARATION OF BID OFFER

- A. Bidders are expected to examine the drawings, specifications, bid documents, proposed contract forms, terms and conditions, and all other instructions and solicitation documents. Bidders are expected to visit the jobsite to determine all requirements and conditions that will affect the work. Failure to do so will not relieve a Bidder from their responsibility to know what is contained in this Invitation for Bid, or site conditions affecting the work.
- B. The Bidder certifies that it has checked all its figures and understands that the City will not be responsible for any errors or omissions on the part of the Bidders in preparing its Bid.

- C. All items, (unless the invitation specifically states otherwise) including any additive or deductive alternates on the Bid Form, must be completely filled out or the Bid will be determined non-responsive and ineligible for consideration for award.
- D. The Bidder declares that the person or persons signing this Bid is/are authorized to sign on behalf of the firm listed and to fully bind the Bidder to all the requirements of the IFB.
- E. The Bidder certifies that no person or firm other than the Bidder or as otherwise indicated has any interest whatsoever in the Bid or the contract that may be entered into as a result of the Bid and that in all respects the Bid is legal and firm, submitted in good faith without collusion or fraud.
- F. By submitting a Bid the Bidder certifies that it has complied and will comply with all requirements of local, state, and federal laws, and that no legal requirements have been or will be violated in making or accepting this Bid. Bidders are expected to review the City's Procurement Rules and Regulations, which will be used when determining whether a Bidder is responsive and responsible and awarding contracts in the best interest of the City.
- G. If there is a discrepancy between the unit price and the total price, the unit price shall be used to determine the applicable total price. Bidders are responsible for including profit and overhead associated with the project when determining their unit prices.

1.15 BASIS OF AWARD

- A. Bid offers that include a base bid and add or deduct alternates will be evaluated and awarded as follows. At bid opening, the City will announce a Budgetary Control Dollar Amount to be used for determining the low bidder. The City intends to award a contract for the base bid item if the Budgetary Control Amount is not exceeded, to the lowest responsive and responsible bidder.
- B. If the Budgetary Control Amount is exceeded by all bidders then the deductive alternate(s) will be subtracted from each bid accordingly and the award made to the resulting lowest responsible bidder that does not exceed the Budgetary Control Amount. The deductive alternates will be deducted in the order in which they appear on the Bid Form.
- C. If the lowest responsible and responsive bid still exceeds the City's budget for these items after the deduct alternate is read, the City reserves the right to reduce estimated quantities to get within the available budget and award a contract that is within budget. B.18.4 only applies to the lowest responsible and responsive bidder at time of bid opening.

1.16 PERIOD OF ACCEPTANCE

The Bidder agrees that its Bid shall remain open for acceptance by the City for a period of sixty (60) calendar days from the date specified in the IFB for receipt of Bids.

1.17 CONTRACT AWARD

The signature of the Bidder indicates that within ten (10) calendar days from acceptance of its Bid, it will execute a contract with the City and, if indicated in this IFB, furnish a project specific Certificate of Insurance naming the City as Additional Insured, furnish Performance, Labor and

Materials, Payment and Maintenance Bonds and any other documents required by the Specifications or Contract Documents.

1.18 NOTICE TO PROCEED

Work may not start under any awarded contract until a written notice to proceed is issued by the City. The City may issue the Notice to Proceed any time after the contract is signed and, if required, insurance and bonds have been provided in accordance with 1.22 below.

1.19 AMENDMENTS TO THE SOLICITATION

Amendments are also referred to as addendum or addenda; and these terms shall be considered synonymous. It is the Bidder's responsibility to contact the Contracts Specialist listed in 1.21 below to confirm the number of Amendments which have been issued.

- A. If this solicitation is amended, then all specifications, terms and conditions, which are not specifically amended, remain unchanged.
- B. Bidders shall acknowledge receipt of any amendment to this solicitation by signing and returning the amendment and by identifying the amendment number and date in the space provided on the form for submitting a Bid.
- C. Acknowledged amendments must be received prior to Bid opening. Bidders are encouraged to include signed addenda or initialed acknowledgment with returned Bids.

1.20 EXPLANATIONS TO PROSPECTIVE OFFERORS

Any prospective Bidder desiring an explanation or interpretation of the IFB documents, drawings, specifications, etc., must request it in writing within ten days of the Bid due date to allow enough time for a reply to reach all prospective offerors before the time for submission of offers. Oral explanations or instructions given before the opening of Bids will not be binding. Any information provided to a prospective Bidder during the Bid preparation stage will be promptly furnished to all other prospective Bidders as an amendment to the solicitation, if that information is necessary in submitting Bids or if the lack of it would be prejudicial to other prospective Bidders.

1.21 QUESTIONS AND OTHER REQUESTS FOR INFORMATION

All questions shall be submitted electronically via the BidNet Direct Procurement Platform (www.bidnetdirect.com) to the following Contract Specialist. All questions must be received no later than **Thursday, February 8, 2024 at 5:00 PM MST.**

Requests for Information, support and questions shall be directed to:

Alyssa Lee
Alyssa.Lee@coloradosprings.gov

DO NOT CONTACT ANY OTHER INDIVIDUAL AT THE CITY OF COLORADO SPRINGS REGARDING THIS SOLICITATION.

1.22 SECURITY REQUIREMENTS

A. Bid Security

1. If the total amount of the accumulative Bid is more than \$50,000, or a bond is required elsewhere in this IFB, the Bidder is required to furnish with their Bid a bid security in the form of a bank certified check, bank cashier's check or a one-time bid bond underwritten by a company licensed to issue bonds in the State of Colorado and acceptable to the City in an amount equal to at least 5% of the total amount of the Bid payable without condition to the City.
2. The Bid security shall guarantee that the Bid will not be withdrawn or modified for a period of sixty (60) calendar days after the time set for the receipt of Bids, and, if the Bid is accepted within those sixty (60) calendar days, that the person, firm or corporation submitting same shall within ten (10) calendar days after being notified of the acceptance of its Bid, enter into a Contract and furnish the required bonds and all insurance certificates called for under this Invitation for Bid.
3. The Bid bonds of unsuccessful Bidders will not be returned to the respective Bidders unless a self-addressed, stamped envelope is provided along with a written request for bid bond return. However, if a certified check or a cashier's check is submitted as Bid security, it will be returned as soon as possible after the lowest responsive and responsible Bidder is determined and a contract is executed.
4. In the event the Bidder whose Bid is accepted fails to enter into the contract and/or furnish the required contract bonds, its certified check, cashier's check or bid bond will be forfeited in full to the City.

B. Performance, Labor and Materials Payment, and Maintenance Bonds

1. For contracts in excess of \$50,000, the Contractor shall furnish to the City each of the following: a Performance Bond, a Labor and Materials Payment Bond, and a Maintenance Bond. Each such bond shall be in the amount of one hundred percent (100%) of the contract price. Bonds shall be submitted within ten (10) calendar days after notification of award of a Contract. The cost of all bonds shall be included in Contractor's Bid.
2. Bonds shall:
 - a. Be for the full amount of the Contract price.
 - b. Guarantee the Contractor's faithful performance of the work under the Contract, and the prompt and full payment for all labor and materials involved therein.
 - c. Guarantee protection to the City against liens of any kind.
 - d. Be from a surety company operating lawfully in the state of Colorado and accompanied by an acceptable "Power-of-Attorney" form attached to each bond copy.
 - e. Be issued from a surety company that is acceptable to the City.
 - f. Be submitted using the forms in the Exhibit section of this IFB or such forms as are approved by the City Attorney's Office.

1.23 SPECIFICATIONS AND DRAWINGS

No Fee solicitations: Specifications and Drawings are normally included in the IFB. If Specifications and Drawings are too large to be included in the IFB, all interested Bidders may obtain one copy of the Project Specifications and a set of the Project Drawings for use in preparing Bids from the City Procurement Services Division office. If the Bidder requires additional sets, it is the Bidder's responsibility to duplicate any additional copies, at its own expense.

1.24 TYPE OF CONTRACT

As a result of this Invitation for Bids, it is the City's intention to award a fixed unit price Contract based on the prices offered by the lowest responsive and responsible bidder. Contract prices shall remain firm and fixed throughout the Contract performance period.

1.25 F.O.B. DESTINATION

Unless otherwise specified in the Invitation for Bid, all goods, materials, supplies, equipment or services covered by this IFB shall be delivered F.O.B. Destination shall be the location indicated in the awarded Contract or Purchase Order.

1.26 BID RESULTS

The City does not mail Bid results or tabulations. However, Bid tabulations are posted and can be downloaded from BidNet. Bidders submitting Bids in response to this solicitation may also request the Bid tabulation for this solicitation via email to the Contracts Specialist indicated as the point of contact for this solicitation.

1.27 APPROPRIATION OF FUNDS

- A. In the event funds are not appropriated in whole or in part sufficient for performance of the City's obligations under this IFB, or appropriated funds may not be expended due the City Charter spending limitations, then the City, without compensation to Bidders, may terminate or cancel this IFB or not award any contracts under this IFB.
- B. In accordance with the Colorado Constitution and City Charter, performance of the City's obligations under any resultant Contract will be expressly subject to appropriations of funds by the City Council, and, in the event the budget or other means of appropriation for any year of the Contract fails to provide funds in sufficient amounts to discharge such obligations, such failure (i) shall act to terminate the Contract at such time as the then-existing and available appropriations are depleted, and (ii) neither such failure nor termination shall constitute a default or breach of the Contract, including any sub-agreement, attachment, schedule, or exhibit thereto, by the City.

1.28 PERIOD OF PERFORMANCE

The Contractor shall complete all work within **200 Calendar Days** after the Notice to Proceed. The Contractor shall start work promptly after receipt of the Notice to Proceed and Pre-Construction Meeting and continue to work diligently until all work is completed and accepted by the City.

1.29 BID DOCUMENTS

The following comprise this Invitation for Bid.

- Schedule A – Bid Form
- Schedule B – General Construction Terms and Conditions
- Schedule C – Special Contract Terms and Conditions
- Schedule D – General Specifications
- Schedule E – Special and Technical Specifications

Schedule F – Scope of Work
Schedule G - Exhibits

The following listed documents must be included with your Bid in order for your Bid submittal to be considered responsive.

Schedule A – Bid Form

Exhibit 2 – Minimum Insurance Requirements Form

Exhibit 3 – Qualification Statement

Exhibit 4 – Bid Certification and Representations and Certifications

Exhibit 5 – Bid Bond if applicable (see 1.23)

Acknowledged Addenda, if issued

SECTION II – SCHEDULES

- Schedule A – Bid Form
- Schedule B – General Construction Terms and Conditions
- Schedule C – Special Contract Terms and Conditions
- Schedule D – General Specifications
- Schedule E – Special and Technical Specifications
- Schedule F – Scope of Work
- Schedule G – Exhibits

SCHEDULE A – BID TAB

Contractor shall provide pricing to furnish all labor, materials, equipment, and supplies required to construct and compete the scope of work. Specifically, the bid includes the following:

Ladders Trail

NOTE: Linear foot quantity estimate for new trail includes the GPS alignment plus 9%

		Quantity	Unit	Unit Price	Extended Price
1	Force Account -	1	LS	\$ \$2,500.00_____	\$ \$2,500_____
2	Construction complete trail for Segment 1 – Ladders Trail 00+00 to 45+74 *	4,986	LF	\$_____	\$_____
3	Construction complete trail for Segment 2 - Ladders Trail 45+75 to 132+75 *	9,483	LF	\$_____	\$_____
4	Provide and install 24" Dia HDPE N12 or equal culvert, 10' length. Install native rock for headwalls above and below pipe	3	EA	\$_____	\$_____
5	Trail Closure and deconstruction as identified on the plan	2,855	LF	\$_____	\$_____
6	Landscape Boulder Retaining Wall, max 48" with on-site native rock and/or provided by the City (Specific to Sites 1, and 2). All other boulders walls with native rock along trail corridor are incidental to the trail segment	155	LF	\$_____	\$_____
7	Slope Erosion Control on Scree Slope – Contractor to provide and place 2" deep topsoil/amendment and EC matting and broadcast seed (City to provide seed) (Site 3)	111	SY	\$_____	\$_____
8	Construct Complete trail reroute, improvements Penrose Trail only (Site 4)	330	LF	\$_____	\$_____
9	Construct Complete trail reroute, improvements, rock armoring and closure on the Captain Jacks Trail only (Site 5)	1	EA	\$_____	\$_____
10	(Site 6) Gold Camp Road Swale crossing improvements. Grade and improve drainage swale and place and install rip rap armoring per plan at Parks to provide rock dumped at the site. Estimated 20 Tons of rock (Does not include Ladders Trail construction in Bid Item #2)	1	EA	\$_____	\$_____
11	Installation of Telespar sleeve and 10' Telespar Post per plan for trail crossings on Gold Camp Road (sign panels to be installed by parks). Posts and hardware provide by City	4	EA	\$_____	\$_____

12	Installation of 10' Telespar post (NO SLEEVE) along the Ladders Trail per the plan. Posts and hardware provided by City	5	EA	\$ _____	\$ _____
13	Installation of 6" x 6" x 6' Composite plastic wayfinding posts per plan. Posts provided by City	6	EA	\$ _____	\$ _____
14	Installation of 60" Fiberglass Carsonite trail marker per plan. Post provided by City.	12	EA	\$ _____	\$ _____

Total Bid Written: _____

Add Alternate #1

NOTE: Linear foot quantity estimate for new trail includes the GPS alignment plus 8%

		Quantity	Unit	Unit Price	Extended Price
A1.1	Grade separated structure for trail crossing at Captain Morgans Trail (Site 2). Price ton include materials, labor, and equipment for installation of structure	1	LS	\$ _____	\$ _____
A1.2	Trail through bed rock requiring additional measures beyond moving boulder and standard excavating to fracture, break or otherwise remove rock to establish a sustainable trail bench. Priced per linear foot	1	LF	\$ _____	\$ _____

Total Base Bid and Ad Alt 1 Written: _____

Add Alternative #2

		Quantity	Unit	Unit Price	Extended Price
A2	Purchase, install and place Geomesh slope protection per detail, includes anchoring and pinning (108 LF x 8.5' wide)	1	LS	\$ _____	\$ _____

Total Base Bid + Ad Alt 1 and 2 Written: _____

SCHEDULE B – GENERAL CONSTRUCTION TERMS AND CONDITIONS

Schedule B -- General Construction Terms and Conditions, Version 100316 are hereby incorporated by reference, with the same force and effect as if they were given in full text. Upon request, the City will make their full text available. Also, the full text of a clause may be accessed electronically at this address:

<https://www.coloradosprings.gov/finance/page/procurement-regulations-and-documents>

The referenced General Construction Terms and Conditions will be incorporated in the resultant Contract.

SCHEDULE C – SPECIAL CONTRACT TERMS AND CONDITIONS/SPECIAL SOLICITATION PROVISIONS

In addition to the special contract terms and conditions listed below, the City's sample contract (see Exhibit 1) contains contract terms and conditions.

ADA STANDARDS

It is a requirement of the City and required by law that any new or renovated facility meet the scoping and technical requirements of the 2010 ADA Standards for newly designed and constructed or altered local government facilities, public accommodations, and facilities. The selected Design Professional shall design the project so it both conforms to the 2010 ADA Standards, as applicable and as amended, and is readily accessible to and usable by individuals with disabilities. The selected Contractor shall build the project so it both conforms to the 2010 ADA Standards, as applicable and as amended, and is readily accessible to and usable by individuals with disabilities. Facilities that are designed, constructed, and/or altered facilities that meet or exceed the IBC 2015/ANSI A117.1 2009, used by Pikes Peak Regional Building Department, will be accepted as meeting or exceeding the 2010 ADA Standards.

SCHEDULE D – GENERAL SPECIFICATIONS

Reserved

SCHEDULE E – SPECIAL AND TECHNICAL SPECIFICATIONS

COS_NCC_LaddersTrailJan2024.pdf follows this page.

NORTH CHEYENNE CANON PARK

LADDERS TRAIL CONSTRUCTION

BID SET JAN 25, 2024

VICINITY MAP

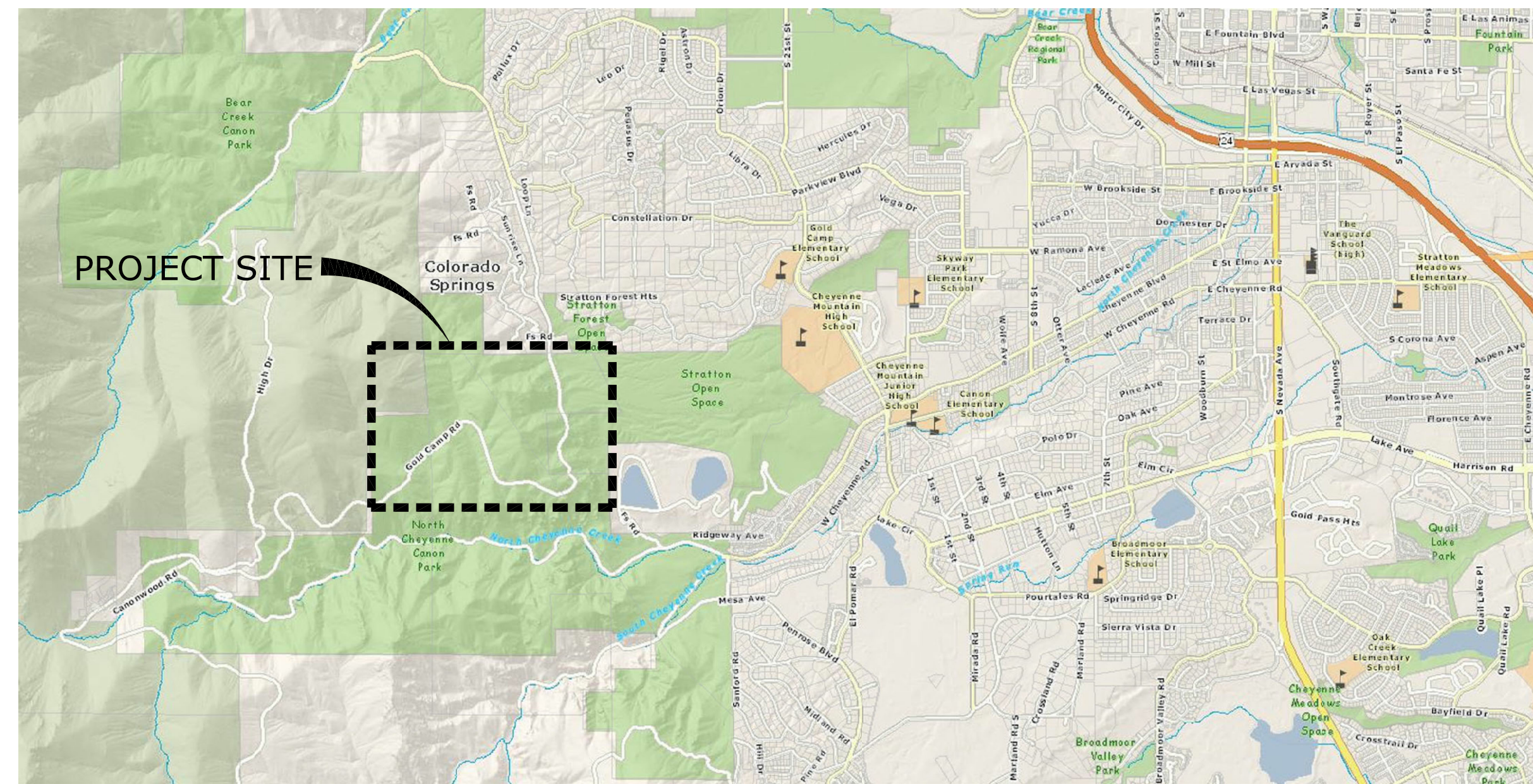

GENERAL NOTES

- It shall be the responsibility of the contractor to verify the existence and location of all underground utilities along the site. The omission from or the inclusion of utility locates on the plans is not to be considered as the non-existence of or a definite location of existing underground utilities.
- The contractor will take the necessary precautions to protect existing utilities, roadway, bridges, and trails from damage due to the construction. Any damaged to the above will be repaired at the contractors expense, and any service disruption will be settled by the contractor.
- All work will take place within North Cheyenne Canon Park, owned and operated by the City of Colorado Springs.
- Stationing has been added to the trail alignment for reference. Tick marks are every 100 feet with every 500 feet labeled. Actual trail length may vary from stationing depicted on the plan.
- North Cheyenne Cañon Park is closed nightly from 10pm to 5am. The contractor will be provided key access to the gates
- Contractor to be responsible for installation and maintenance of all trail closures, temporary signage, temporary fencing and other devices to keep the public out of the work area. The contractor to coordinate with city for the closure of Gold Camp Road when construction activities occur in the debris risk zones as shown on the map.
- City to coordinate construction activities and closure notes with the public via social media and press releases.
- Contractor may leave equipment on site at their own risk. Additional protective measure of gear/equipment, like temporary fencing, may be considered at the contractors expense.
- Some locations of the project site may be subject to higher risk of construction debris sloughing or rolling downhill to Gold Camp Road. While there is always a risk with material rolling downhill (and should be mitigated at all times by contractor), the high risk areas have been shown on the map. They include the following:

Construction Debris Risk
Above Gold Camp Road

Yellow: LOWER RISK - less steep slopes, more vegetative barriers, more distance to road

Orange: ELEVATED RISK, steep slopes, less vegetative barriers, more direct run outs to road

Red: HIGH RISK, steep slopes, no vegetative barriers, direct run outs to road

Gold Camp Road may be permitted to close when building in these areas. Contractor ensure debris on roadway is cleared as soon as possible and that road remains passable for emergency vehicles at all times. Closures windows to consider the busy season, to limit public access impact.

SHEET INDEX

1 of 11:	Cover Sheet
2 of 11:	Overview Map
3 of 11:	Station 00+00 - 35+00
4 of 11:	Station 35+00 - 57+00
5 of 11:	Station 57+00 - 73+00
6 of 11:	Station 73+00 - 90+00
7 of 11:	Station 90+00 - 110+00
8 of 11:	Station 110+00 - 131+00
9 of 11:	Station 131+00 - 152+00
10 of 11:	DETAILS
11 of 11:	DETAILS



Design and Development
& TOPS
1401 Recreation Way
Colorado Springs, CO 80905
Tel. 719.385-6540
Fax 719.385.6599

© 2022. All Rights Reserved.

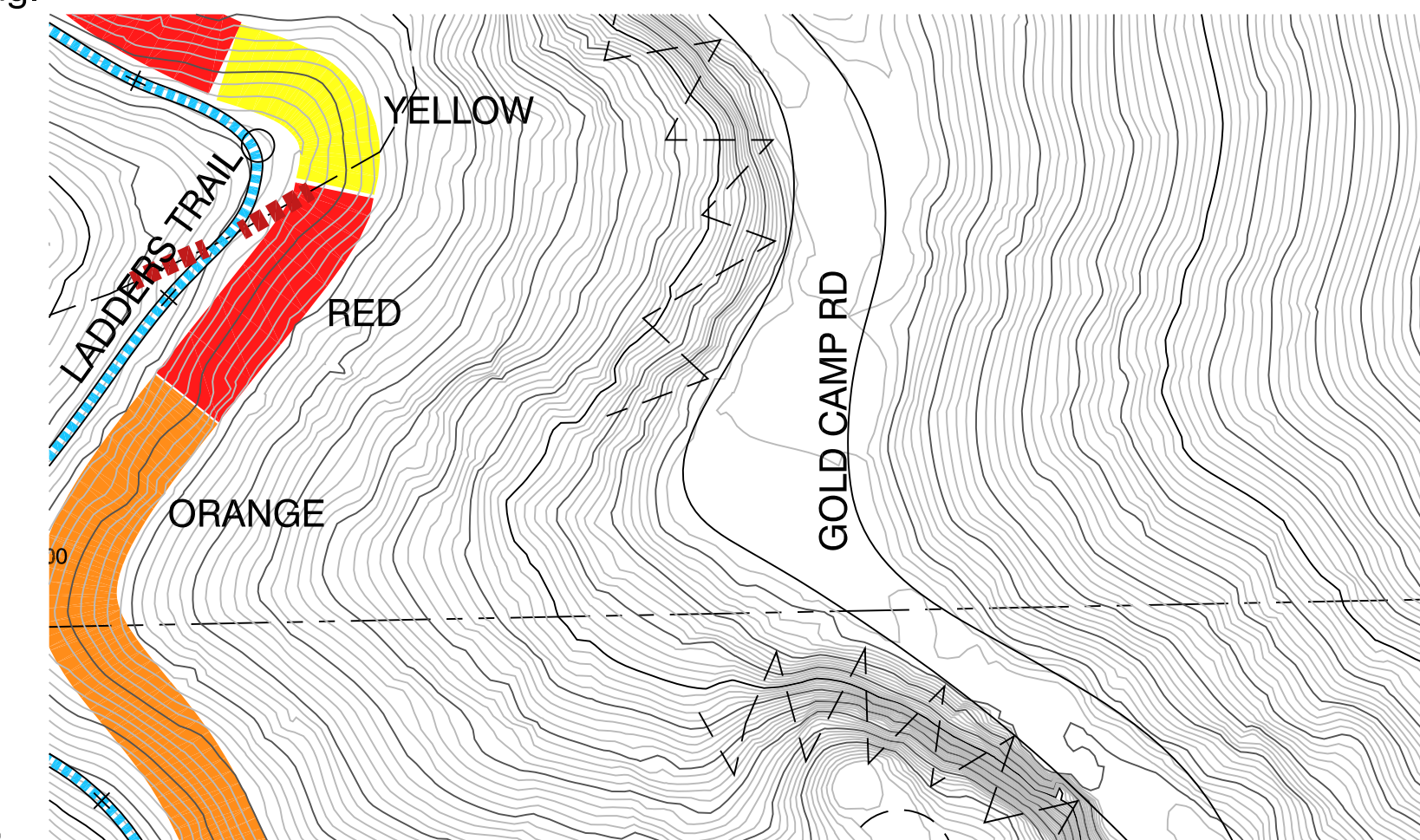

North Cheyenne Cañon Park Ladders Trail Improvement

WAYFINDING POST DETAIL

PLASTIC TIMBER WAYFINDING POST (STANDARD INSTALL)

- WAYFINDING POST INSTALLATION NOTES
- POST HOLES TO BE DUG TO A MINIMUM 36" DEPTH. CONTRACTOR MAY SELECT THE MOST EFFICIENT AND COST EFFECTIVE APPROACH WITHIN REASON TO DIG THE HOLE. POST SHALL BE BACKFILLED WITH COMPACTED NATIVE SOIL.
 - POSTS SHALL BE LOCATED A MINIMUM 24" FROM EDGE OF TRAIL.
 - TOTAL POST HEIGHT ABOVE GROUND SHALL BE 36" AND A DEPTH OF 36".
 - CONTRACTOR SHALL INSTALL AND ATTACH THE METAL SLEEVE (PROVIDED BY CITY). WAYFINDING DECALS WILL BE INSTALLED BY CITY.
 - LITTLE TO NO INSTALLATION ON ROCK IS ANTICIPATED
 - POST AND SLEEVES PROVIDED BY CITY. BOTH ARE AVAILABLE AT 1401 RECREATION WAY FOR PICK UP.

CARSONITE TRAIL SIGN POST (STANDARD INSTALL)

- CARSONITE POST INSTALLATION NOTES
- ALL CARSONITE POST TO BE PROVIDED BY CITY
 - POST HOLES TO BE DUG/INSTALLED TO A MINIMUM 20" DEPTH. BACKFILL WITH COMPACT NATIVE SOIL.
 - TOTAL POST HEIGHT ABOVE GROUND SHALL BE NO MORE THAN 42" HEIGHT.
 - POSTS SHALL BE LOCATED A MINIMUM 12" FROM EDGE OF TRAIL.
 - THE CONTRACTOR IS NOT RESPONSIBLE FOR PLACEMENT OF THE STICKER DECALS. THE CITY WILL INSTALL THE WAYFINDING DECALS AT A LATER TIME.
 - LITTLE TO NO INSTALLATION ON ROCK IS ANTICIPATED IN ROCK

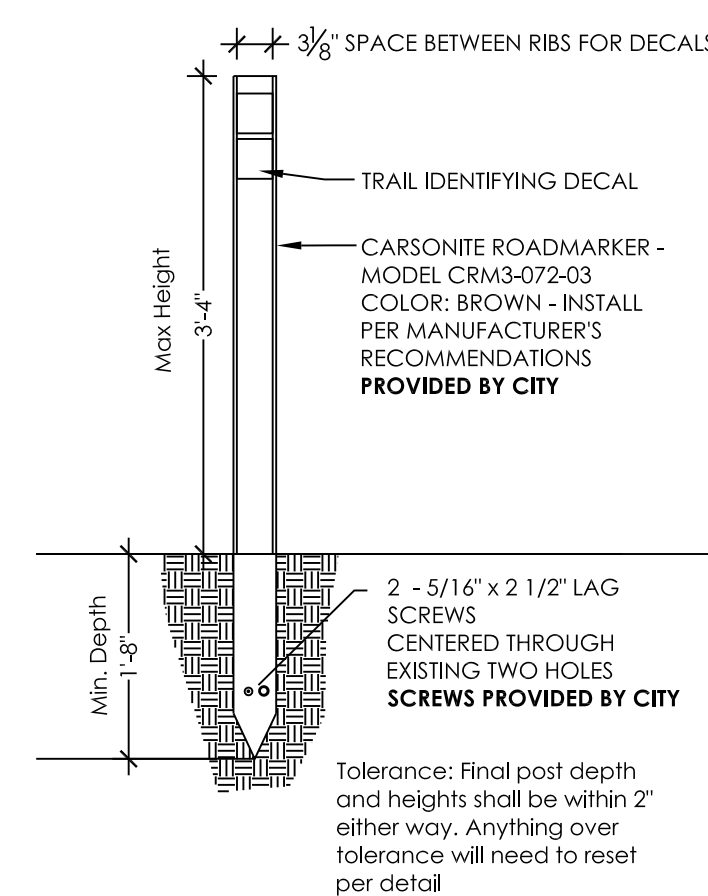
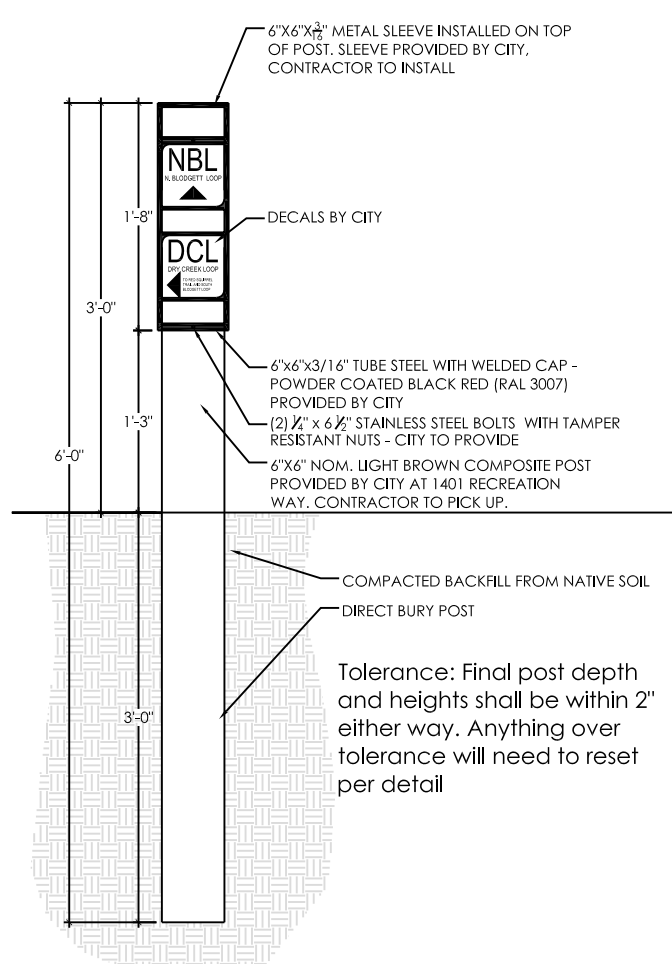

Slope Stability

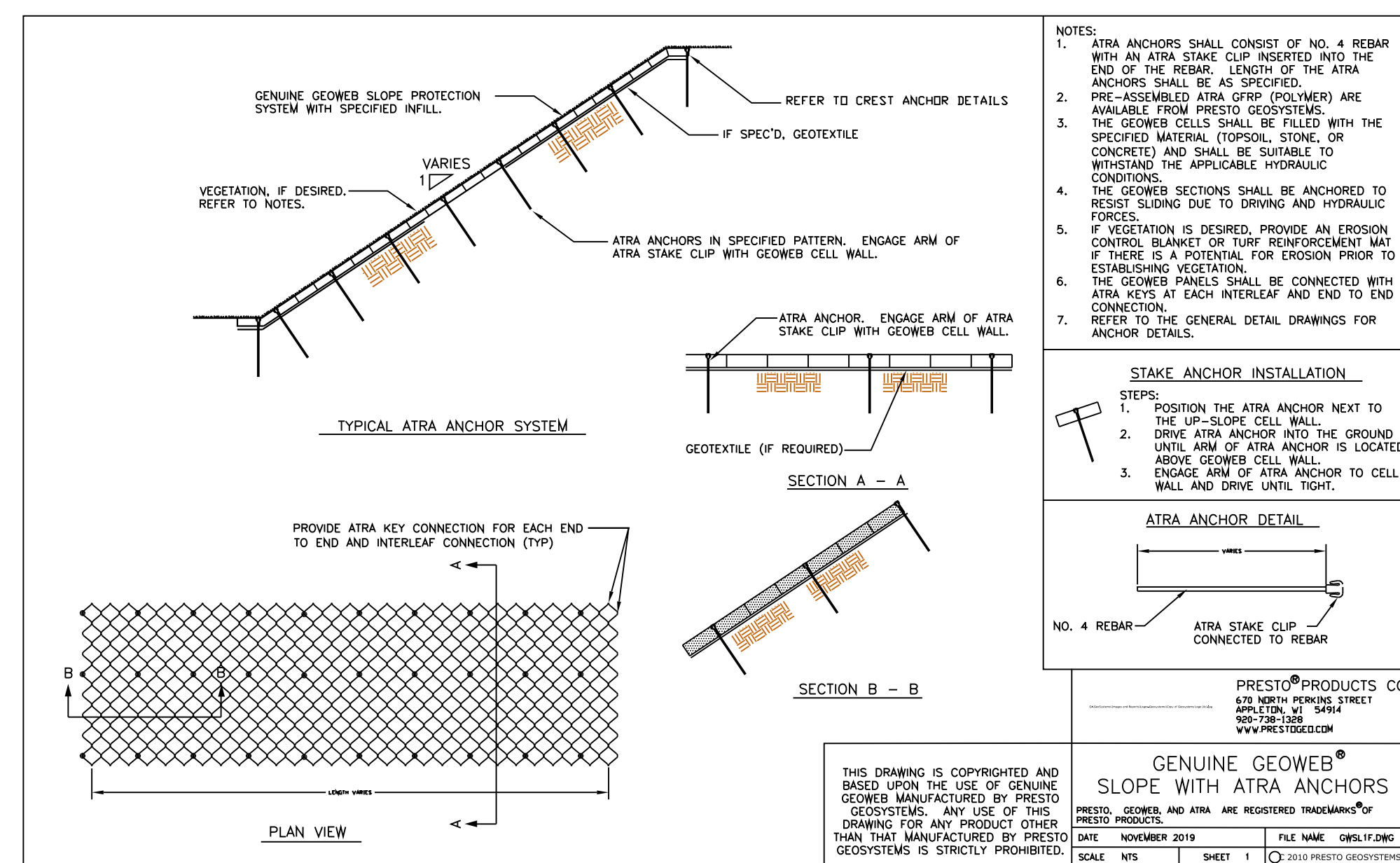

GeoWeb stability material

Slope Stability Add Alternates For 'Site 3'

- Base Bid to include standard trail construction with the installation and placement of 2" depth of topsoil, seed and erosion control blanket.
- Ad Alt 2 includes the installation of the GeoWeb netting per the detail at the trail tread. GeoWeb provided by the City. Topsoil, seeding, and erosion control netting to be installed o top of installed GeoWeb.

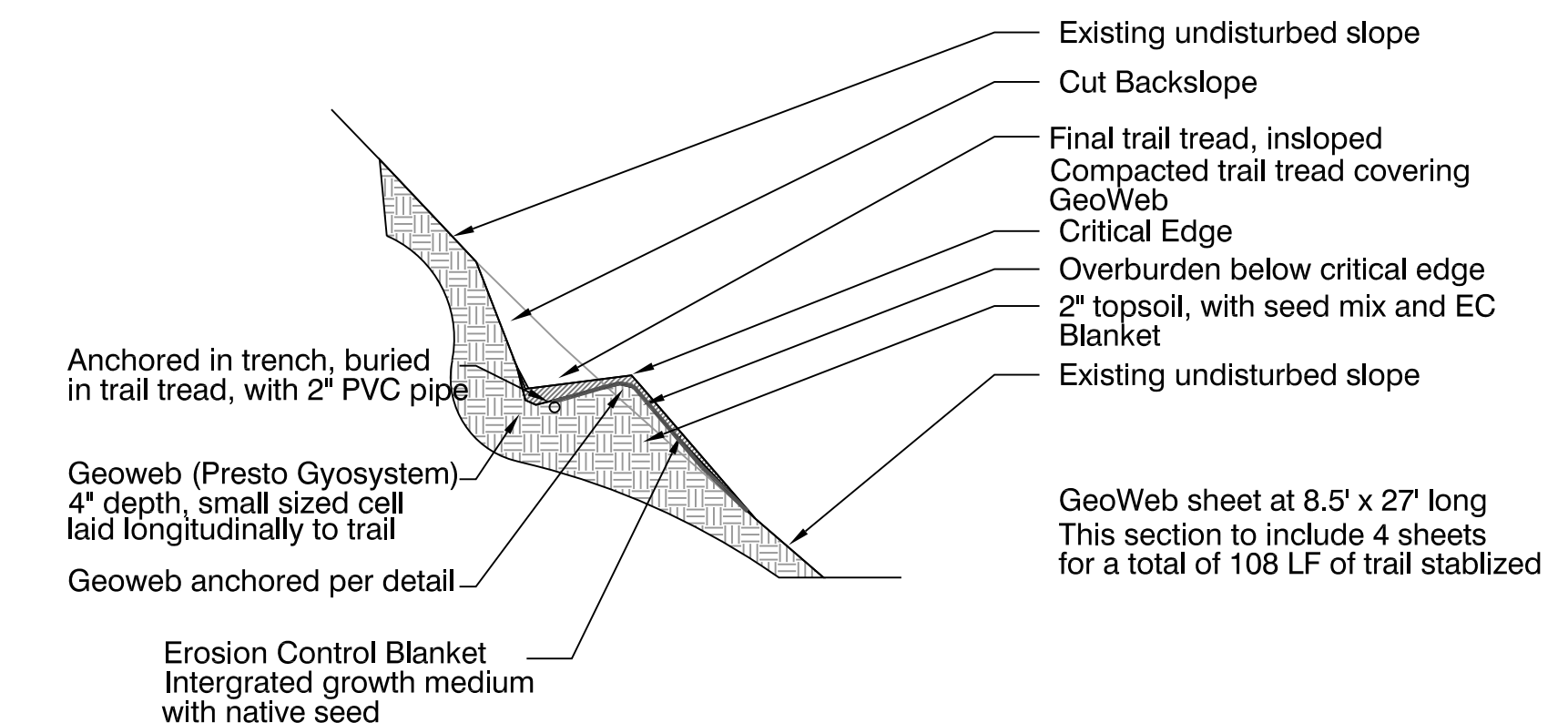

GeoWeb stability material in trail tread

DATE: JAN 24, 2024
PROJECT MGR.: D. Deltmeyer
PREPARED BY: D. Deltmeyer

DATE: BY: DESCRIPTION:

Cover

1

11 OF

LANDSCAPE ARCHITECT

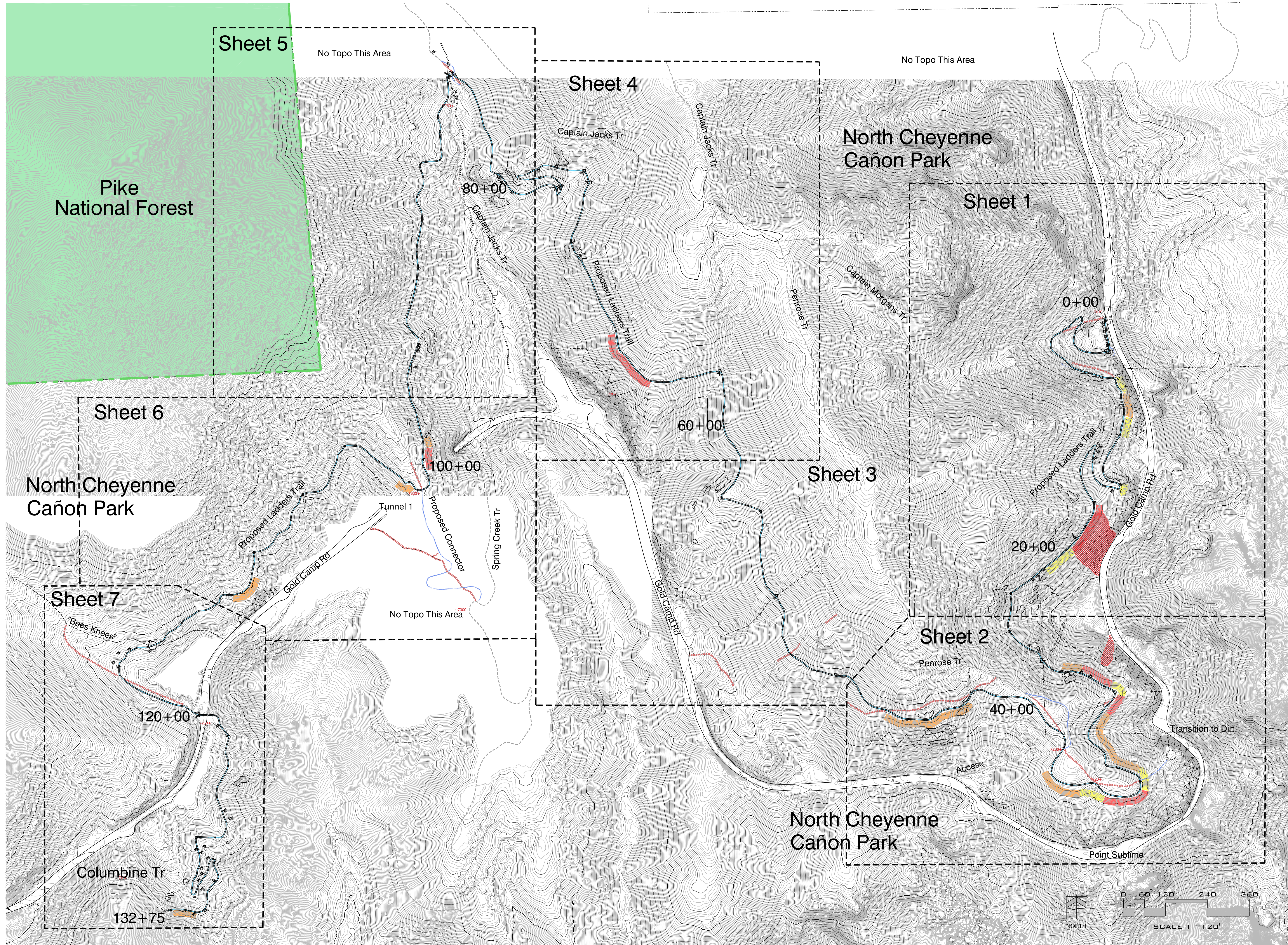

North Cheyenne Cañon Park Ladders Trail Improvement

DATE:	Aug 4, 2023
PROJECT MGR.:	D. Deltmeyer
PREPARED BY:	D. Deltmeyer

SCALE

ISSUE INFO

DATE:	BY:	DESCRIPTION:

ISSUE REVISION

SHEET TITLE

SHEET NUMBER

PROJECT MAP

2

11 OF

C:\Design\New\Regional\NorthCheyenneCañon\General Information\Trail Development\Ladders_Corvey\AutoCAD\Ladders_Extension_Base (Rising) (D:\HCC\Project Map) 1/27/2024 3:36:45 PM ddeltemeyer

**North Cheyenne Cañon Park
Ladders Trail
Improvement**

DATE: Aug 4, 2023
PROJECT MGR.: D. Dittermeyer
PREPARED BY: D. Dittermeyer

DATE:	BY:	DESCRIPTION:

Map Sheet 1

3

11 OF

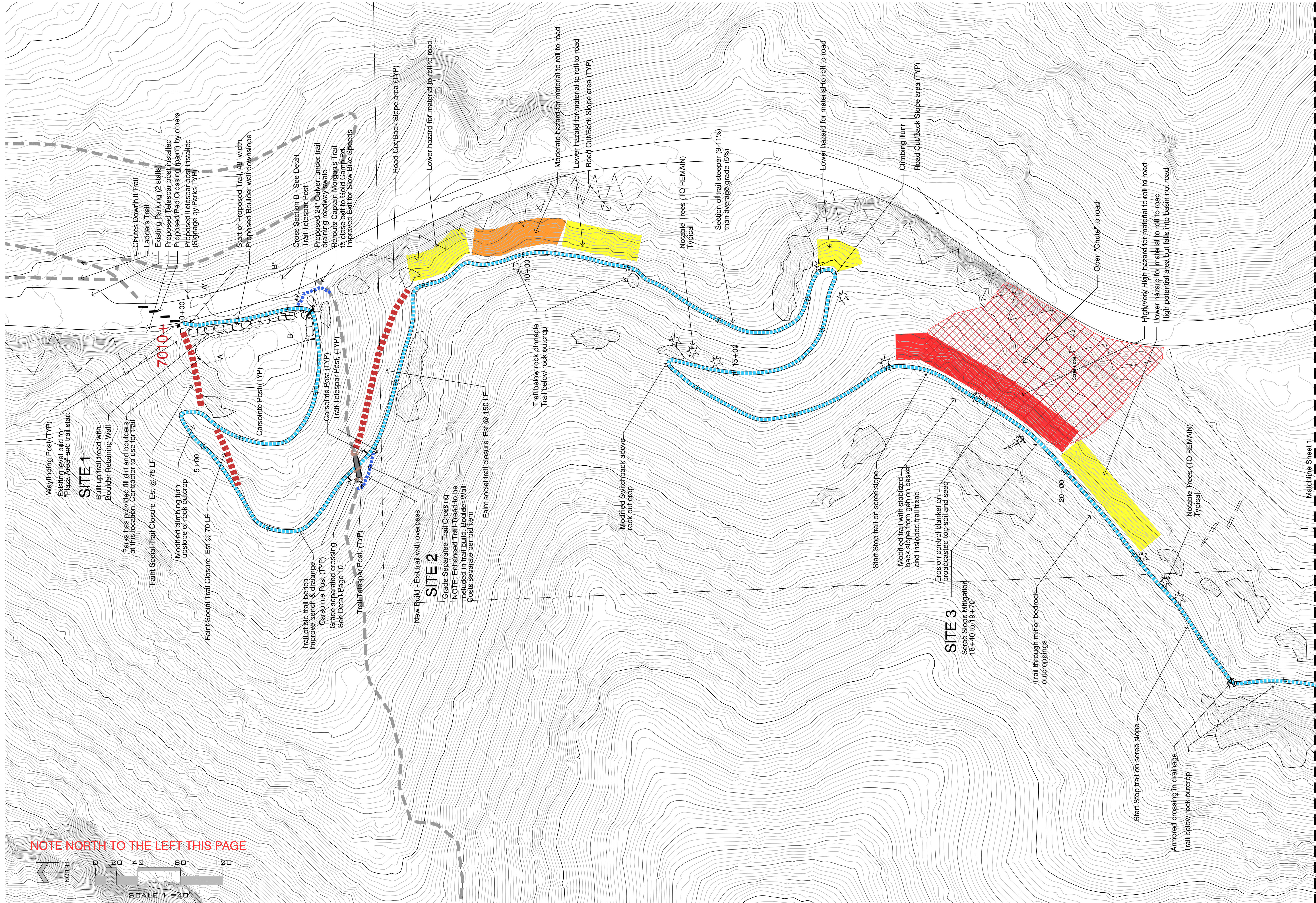

A:\Design\Dev\Regional\Barks\NorthCheyenneCañon\General Information\Trail Development\Ladders_Corral_AutoCAD\Ladders_Extension_base (file.dwg) [Segment: 1 ROT] 1/24/2024 3:38:22 PM ddittermeyer

North Cheyenne Cañon Park Ladders Trail Improvement

DATE: Aug 4, 2023
PROJECT MGR.: D. Deltenermeyer
PREPARED BY: D. Deltenermeyer

DATE: BY: DESCRIPTION:

Map Sheet 2

4

11 OF

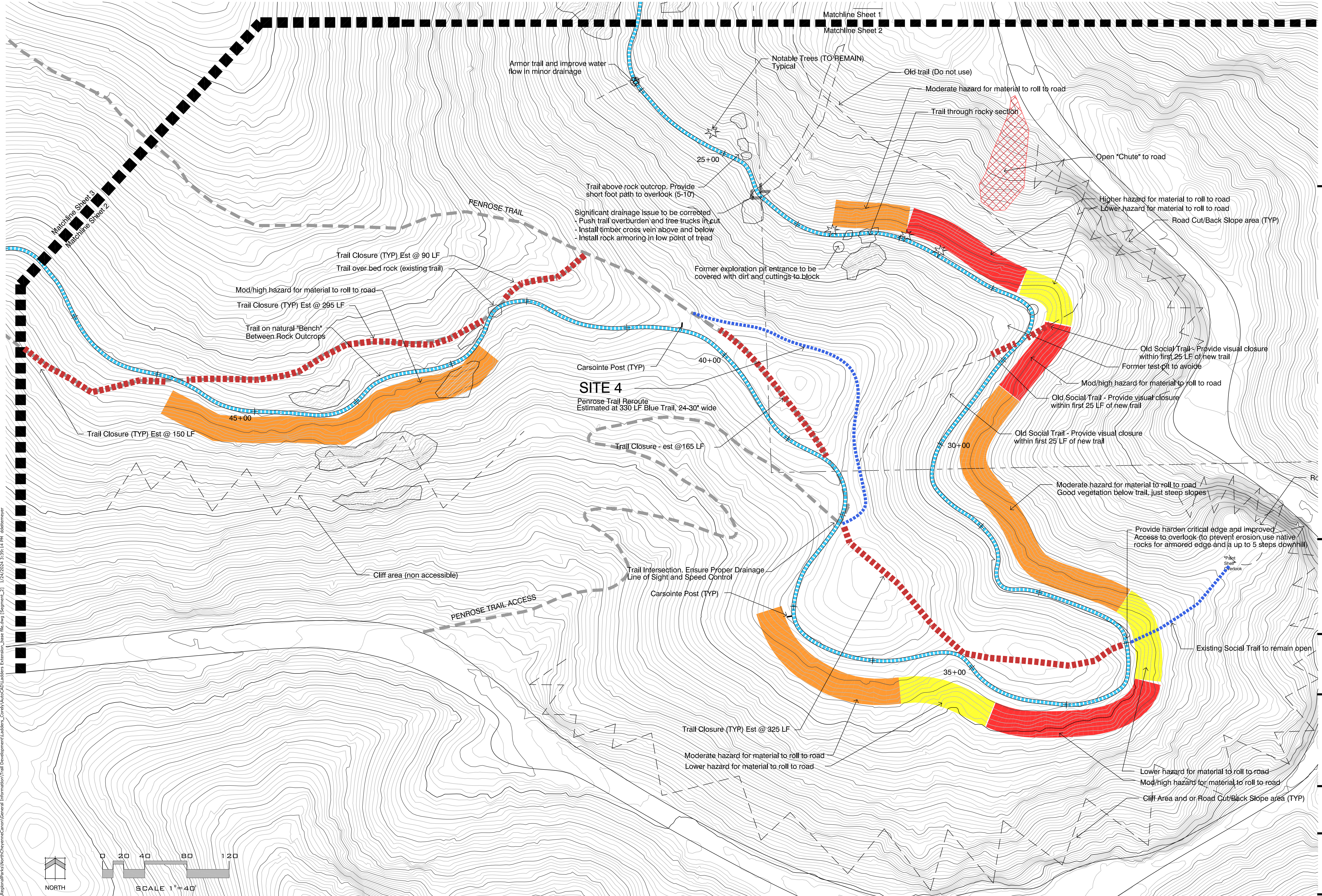

A:\Design\Dev\Regional\NorthCheyenneCañon\General Information\Trail Development\Ladders Trail Improvement_base file.dwg [Segment_2] 1/24/2024 3:39:14 PM ddeltenermeyer

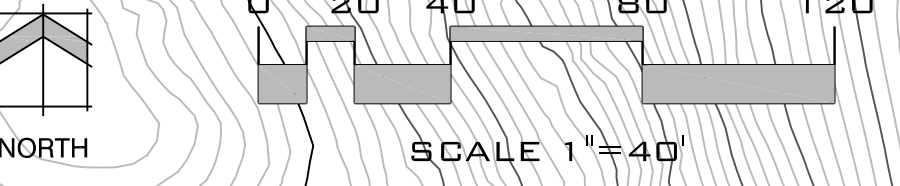

LANDSCAPE ARCHITECT

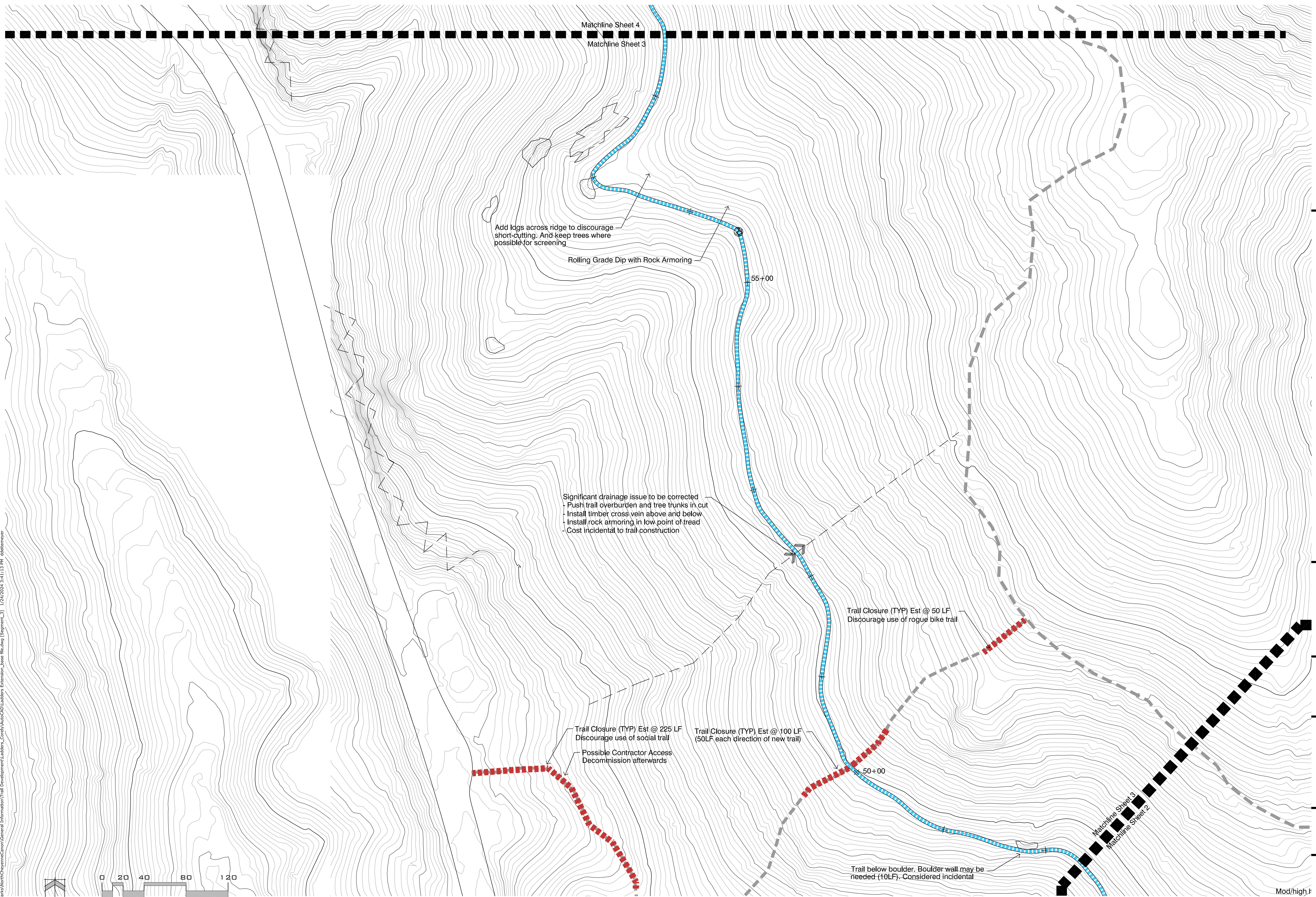

A:\Design\Projects\NorthCheyenneCañon\General Information\Trail Development\Ladders_Creek\AurCAD\Ladders_Extension_base (file.dwg) [Segment_3] 1/24/2024 3:41:13 PM ddellemeyer

**North Cheyenne Cañon Park
Ladders Trail
Improvement**

PROJECT INFO
DATE: Aug 4, 2023
PROJECT MGR.: D. Deltmeyer
PREPARED BY: D. Deltmeyer

DATE:	BY:	DESCRIPTION:

Map Sheet 3

5

11 OF

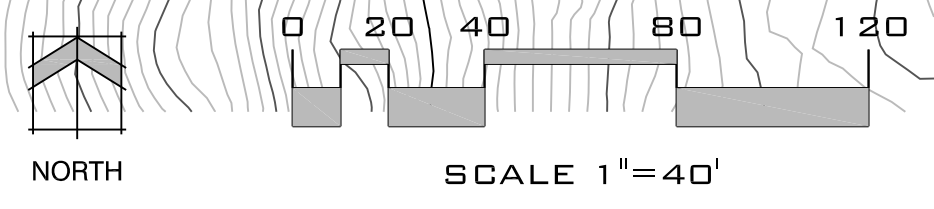

**North Cheyenne Cañon Park
Ladders Trail Improvement**

PROJECT INFO
DATE: Aug 4, 2023
PROJECT MGR.: D. Dittermeyer
PREPARED BY: D. Dittermeyer

SEAL

ISSUE INFO

DATE:	BY:	DESCRIPTION:

Map Sheet 4

6

11 OF

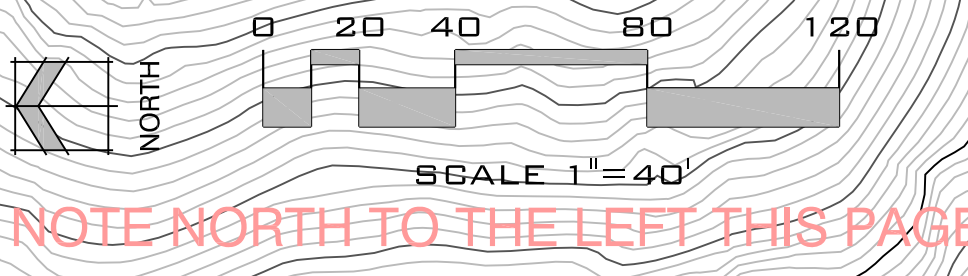
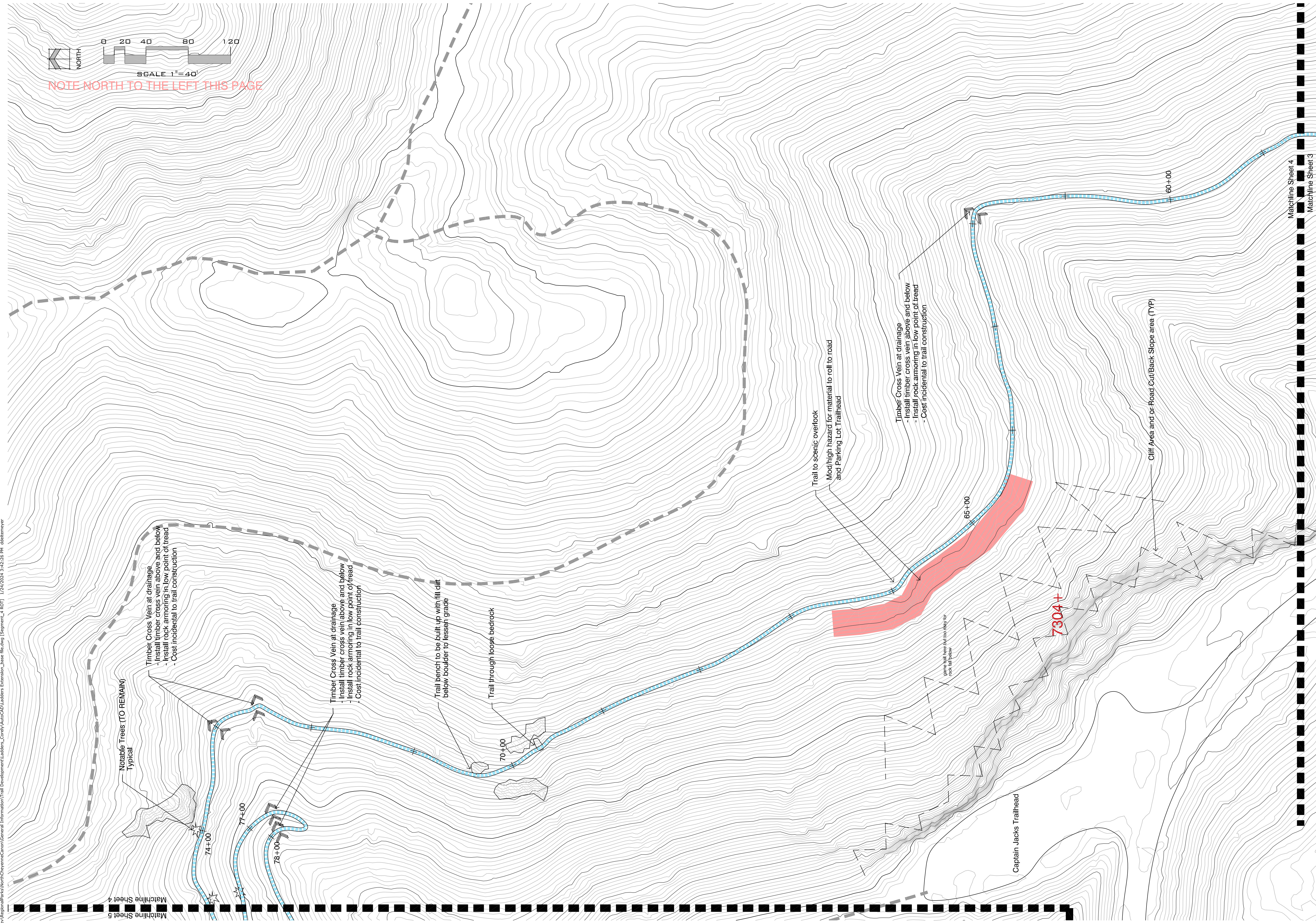

NOTE NORTH TO THE LEFT THIS PAGE

A:\Design\RegionalParks\NorthCheyenneCañon\General Information\Trail Development\Ladders_Corral_AutoCAD\Ladders_Extension_base_files.dwg [Segment_4_R0T1] 1/24/2024 3:42:26 PM ddittermeyer

LANDSCAPE ARCHITECT

**North Cheyenne Cañon Park
Ladders Trail Improvement**

PROJECT INFO
DATE: Aug 4, 2023
PROJECT MGR.: D. Deltmeyer
PREPARED BY: D. Deltmeyer

SEAL

ISSUE INFO

DATE:	BY:	DESCRIPTION:

Map Sheet 5

7
11 OF

SHEET NUMBER

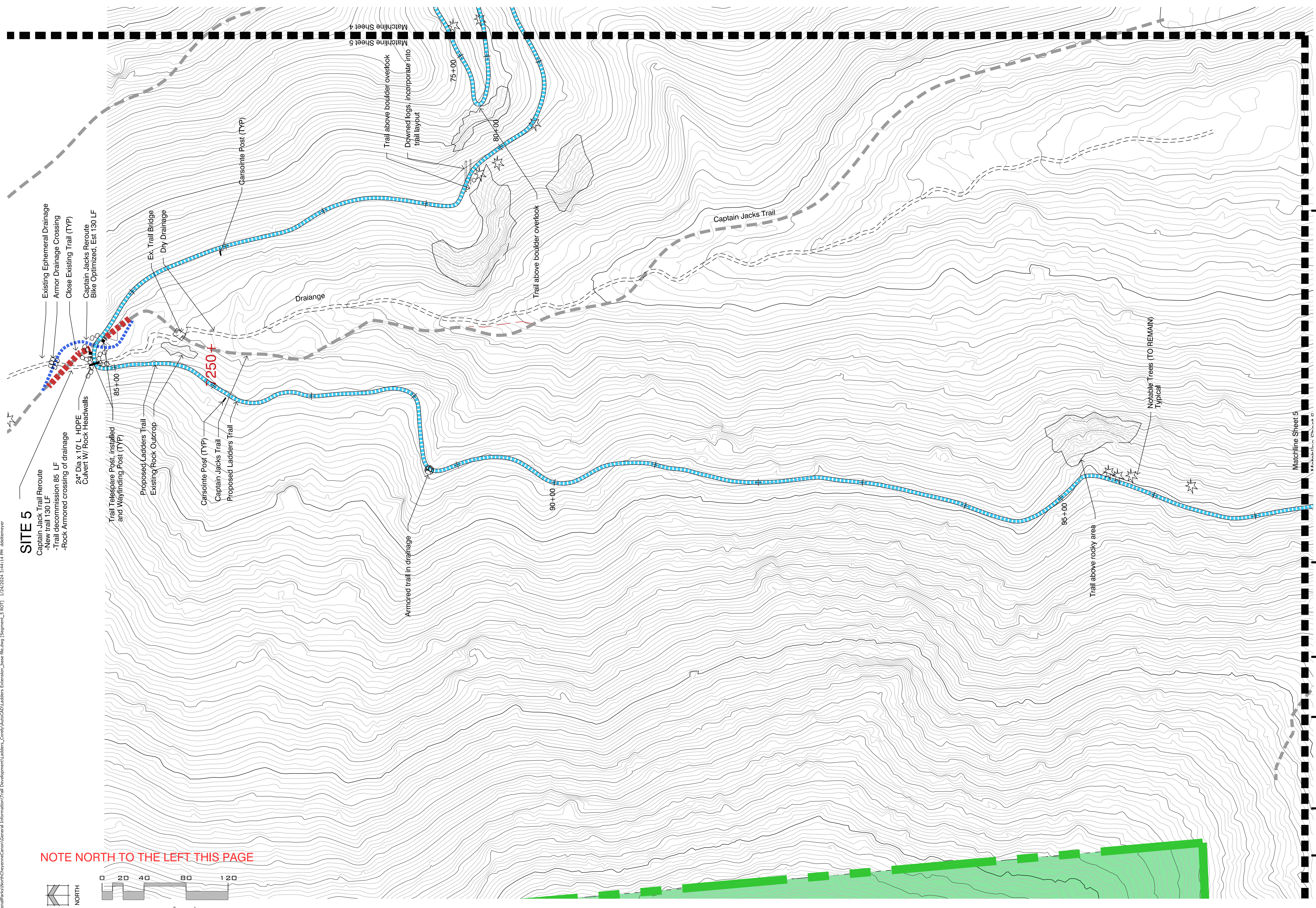

SITE 5

- Captain Jack Trail Reroute
- New trail 130 LF
- Trail decommission 85 LF
- Rock Armored crossing of drainage
- 24" Dia x 10' L HDPE Culvert w/ Rock Headwalls
- Trail Telescope Post, installed and Weyfing Post (TYP)
- Proposed Ladders Trail Existing Rock Outcrop
- Carsointe Post (TYP)
- Captain Jacks Trail
- Proposed Ladders Trail
- Trail above boulder overbook
- Downed logs, incorporate into trail layout
- Trail above boulder overbook
- Trail above rocky area
- Notable Trees (TO REMAIN) Typical
- Carsointe Post (TYP)
- Close Existing Trail (TYP)
- Armor Drainage Crossing
- Existing Ephemeral Drainage
- Captain Jacks Reroute Bike Optimized, Est 130 LF
- Armor Drainage Crossing
- Trail Telescope Post, installed and Weyfing Post (TYP)
- Proposed Ladders Trail Existing Rock Outcrop
- Carsointe Post (TYP)
- Captain Jacks Trail
- Proposed Ladders Trail
- Trail above boulder overbook
- Downed logs, incorporate into trail layout
- Trail above boulder overbook
- Trail above rocky area
- Notable Trees (TO REMAIN) Typical

NOTE NORTH TO THE LEFT THIS PAGE

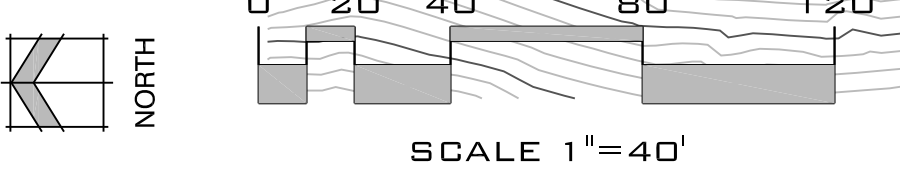

A:\Design\Dev\RegionalParks\NorthCheyenneCañon\General Information\Trail Development\Ladders_Core\AutoCAD\Ladders_Extension_base (file.dwg) [Segment_5_R0T] 1/27/2024 3:44:14 PM ddeltmeyer

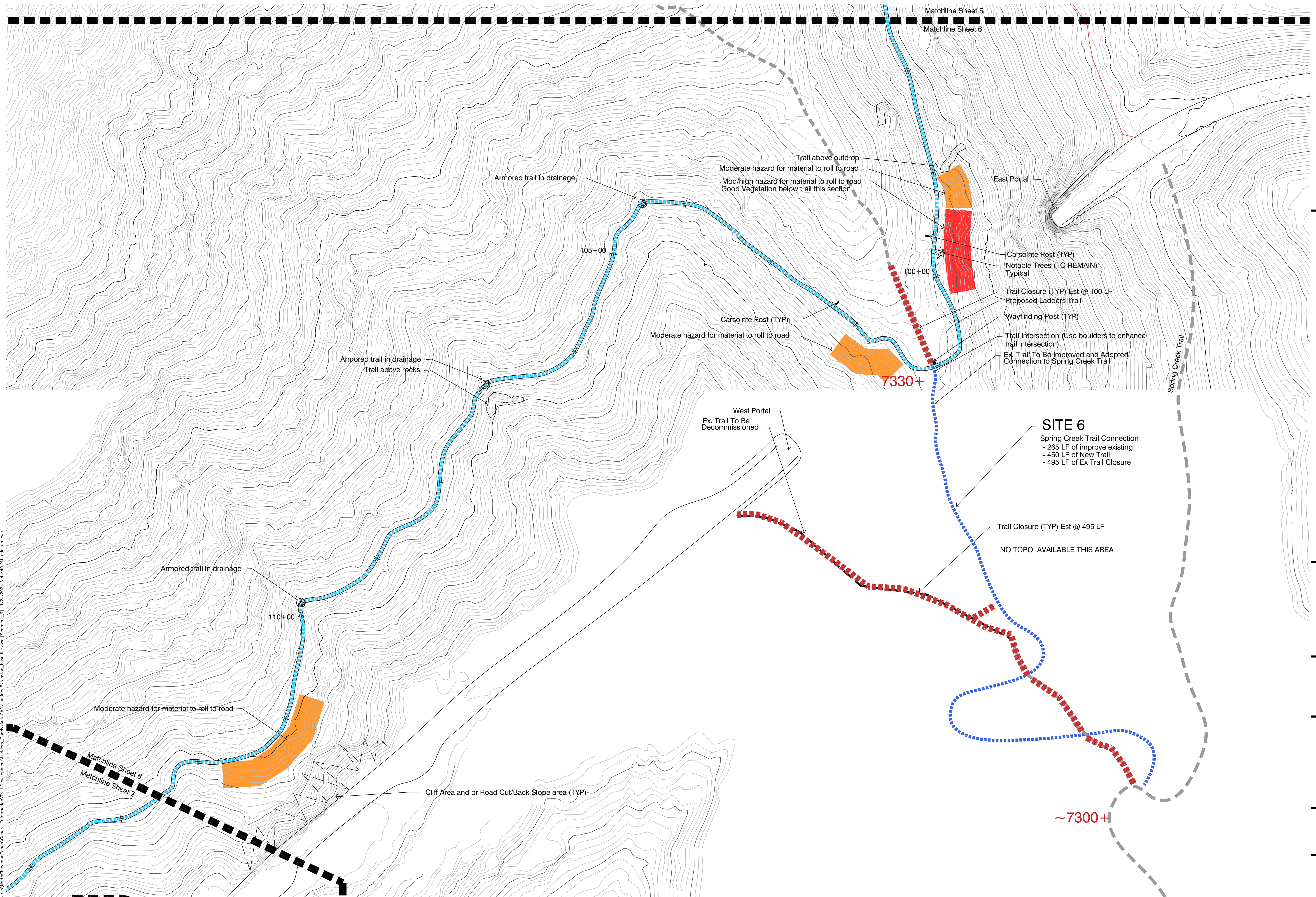

North Cheyenne Cañon Park Ladders Trail Improvement

SITE 6
Spring Creek Trail Connection
- 265 LF of improve existing
- 450 LF of New Trail
- 495 LF of Ex Trail Closure

Trail Closure (TYP) Est @ 495 LF
NO TOPO AVAILABLE THIS AREA

PROJECT INFO	DATE:	Aug 4, 2023
	PROJECT MGR.:	D. Deltmeyer
	PREPARED BY:	D. Deltmeyer

DATE:	BY:	DESCRIPTION:

Map Sheet 6

8

11 OF

A:\Design\Dev\Regional\Bikes\NorthCheyenneCañon\General Information\Trail Development\Ladders_Creek\AutoCAD\Ladders_Extension_base (file.dwg) [Segment_6] 1/24/2024 3:44:40 PM ddeltmeyer

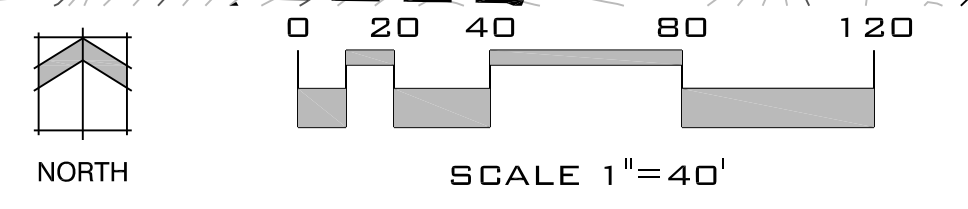

A:\Design\RegionalParks\NorthCheyenneCañon\General Information\Trail Development\Ladders_Corral\AutoCAD\Ladders_Extension_base (file.dwg) [Segment_7607] 1/24/2024 3:45:02 PM ddellemeyer

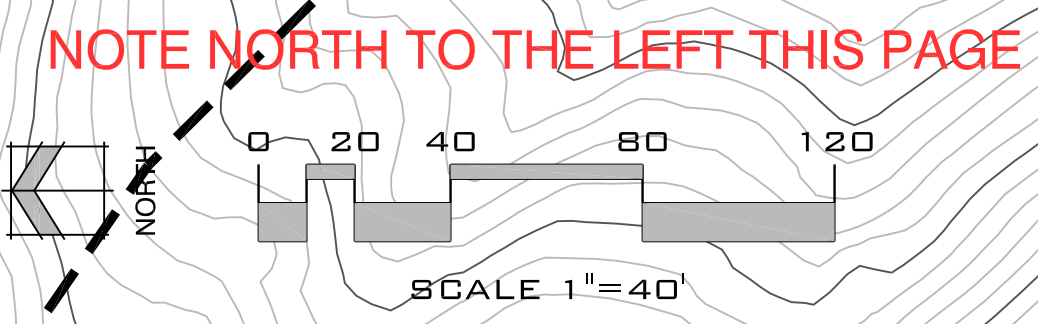
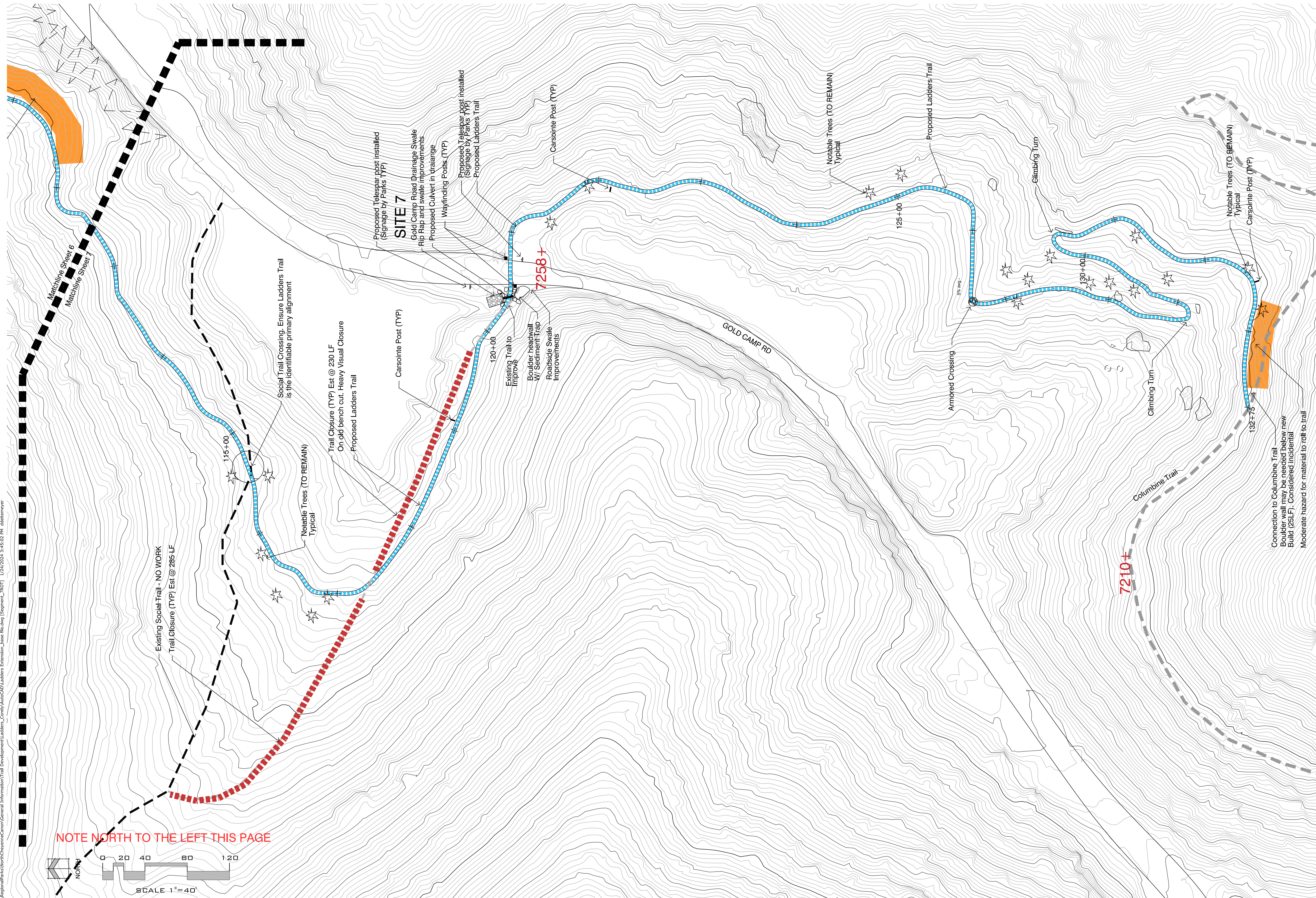

parcs · recreation · cultural services

Design and Development & TOPS
1401 Recreation Way
Colorado Springs, CO 80905

Tel. 719.385.6540
Fax 719.385.6599

© 2022. All Rights Reserved.

North Cheyenne Cañon Park Ladders Trail Improvement

PROJECT INFO
DATE: Aug 4, 2023
PROJECT MGR.: D. Deltmeyer
PREPARED BY: D. Deltmeyer

SEAL

ISSUE INFO

DATE:	BY:	DESCRIPTION:

SHEET TITLE

Map Sheet 7

SHEET NUMBER

9

11 OF

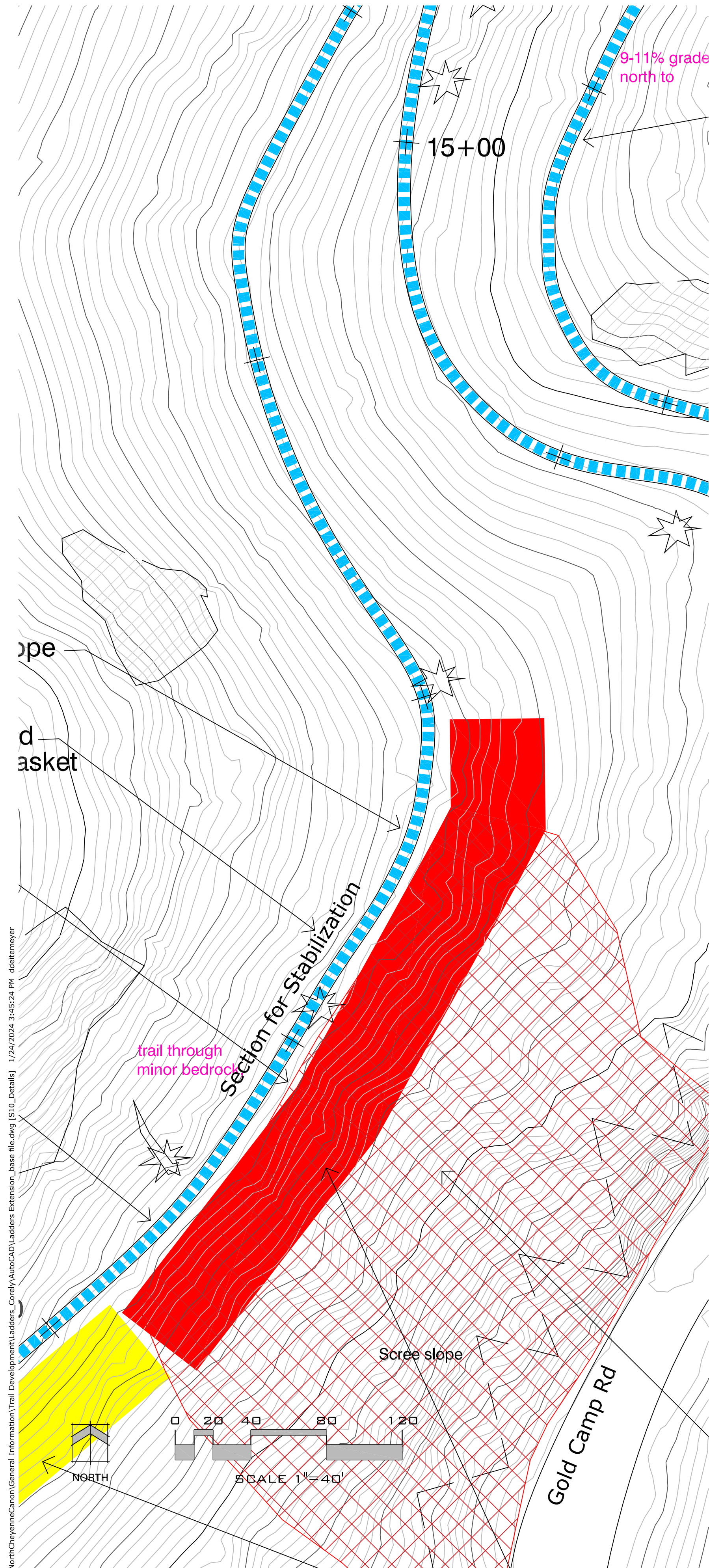

Trail Cross Section A: Near Start of Trail

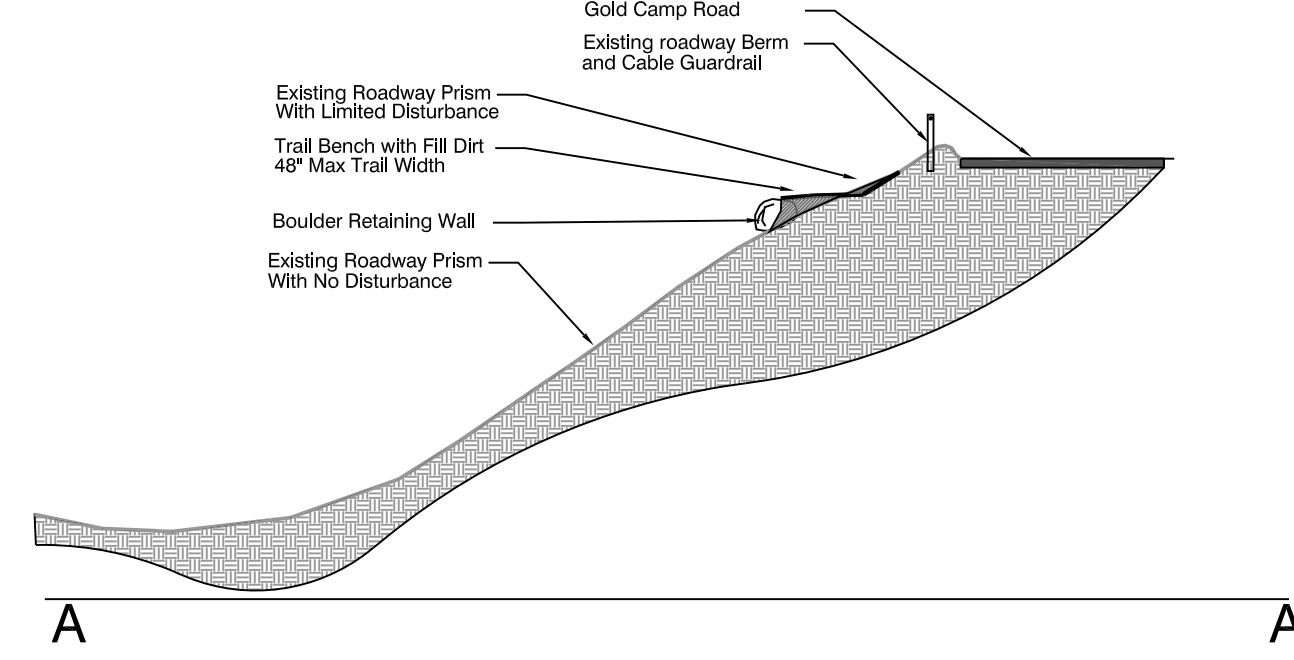

Trail Cross Section B: Typical Sideslope

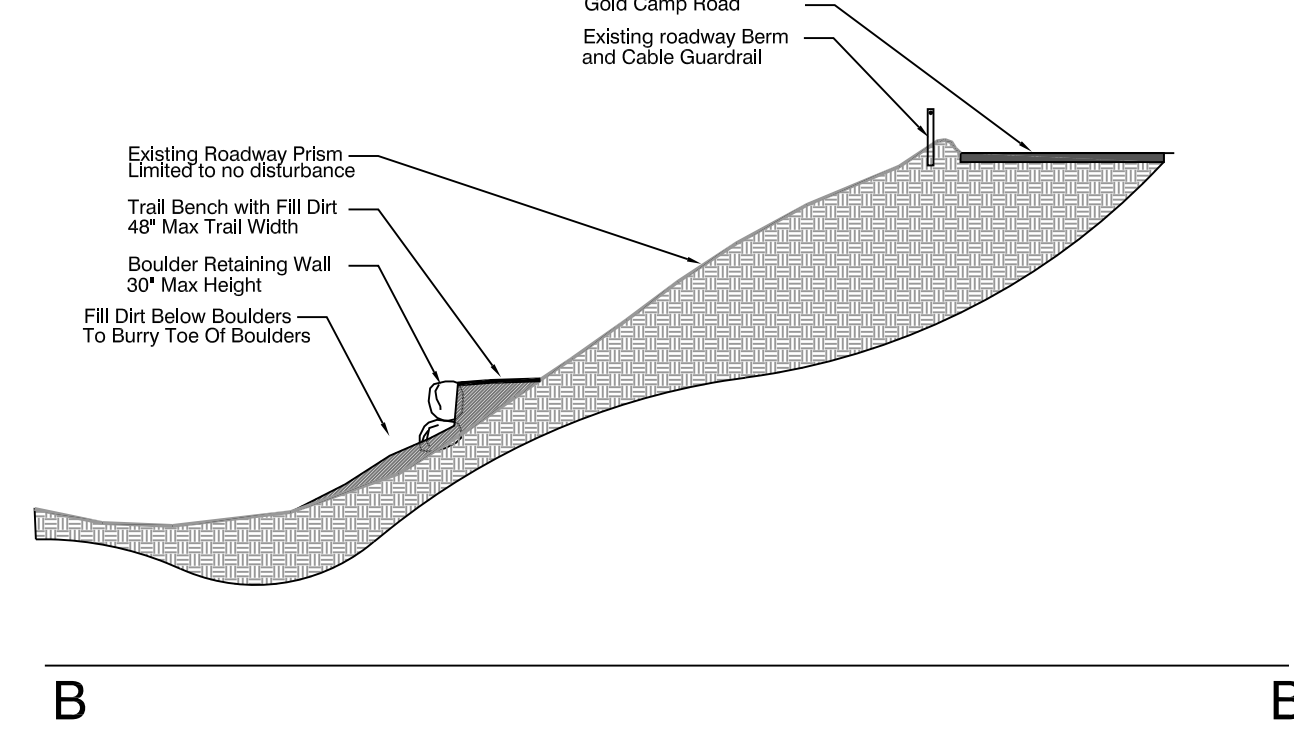

Technical Details

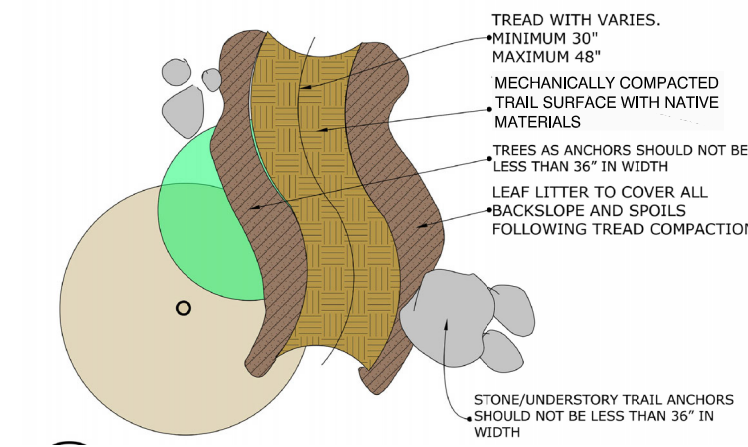

3 Plan Detail: Typical Trail
6 Not To Scale

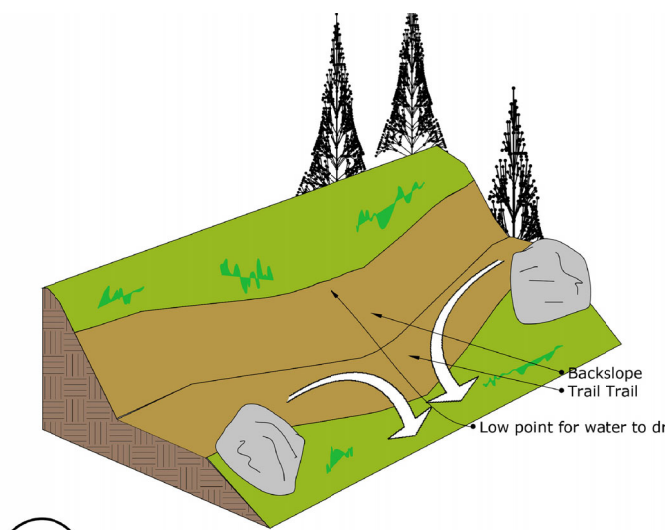

4 Section Detail: Grade Reversal
10 Not To Scale

1 Ephemeral Drainage Crossing with Timber Cross Vein
10 Not To Scale

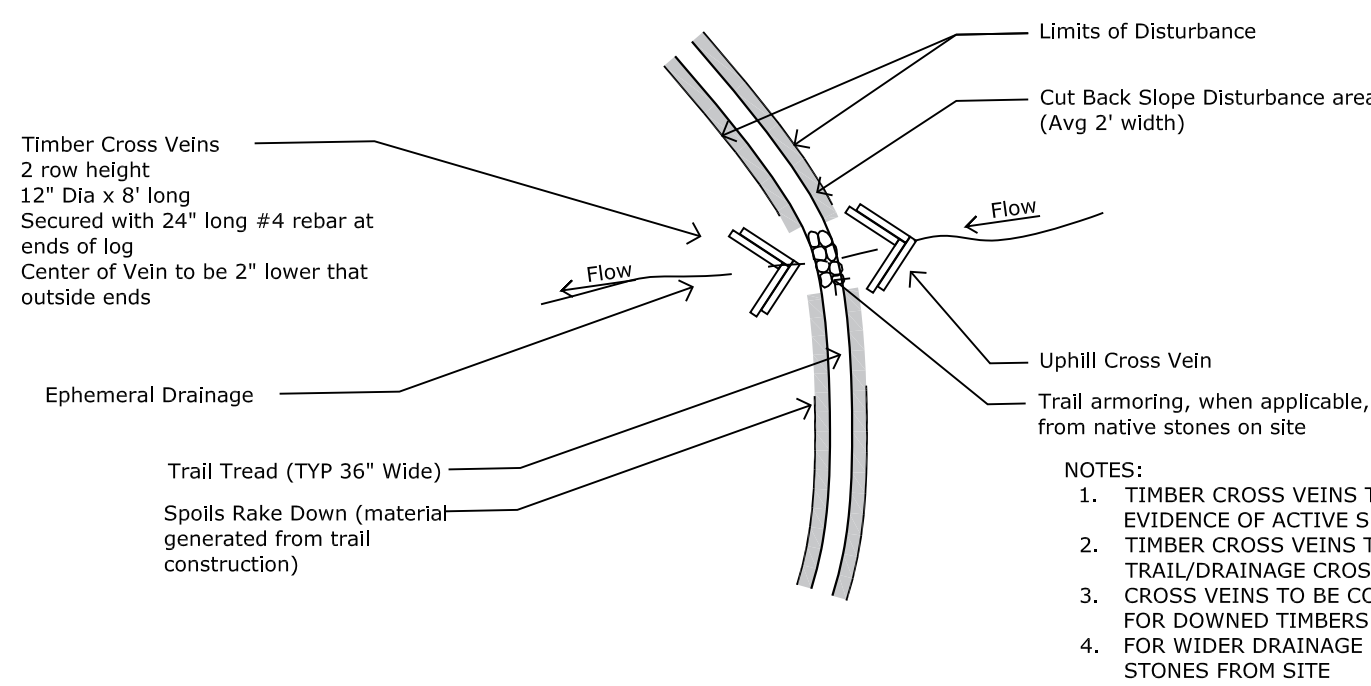

2 Ephemeral Drainage Crossing with Timber Cross Vein
10 Not To Scale

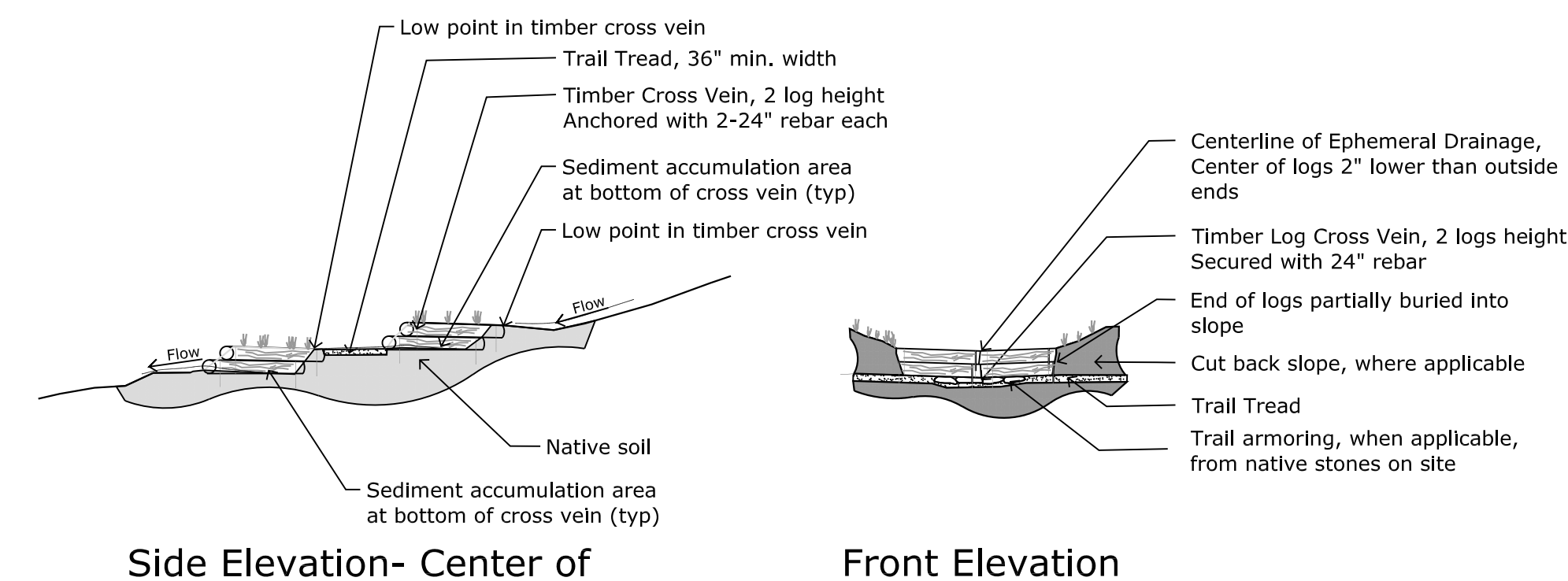

Side Elevation- Center of

Front Elevation

6 Ephemeral Drainage Crossing with Timber Cross Vein
10 Not To Scale

5 Slope Stability Section Enlargement
10 Not To Scale

7 Timber Cross Vein Example - Look uphill from trail tread
10 Not To Scale



North Cheyenne Cañon Park Ladders Trail Improvement

DATE: Aug 4, 2023
 PROJECT MGR.: D. Deltenermeyer
 PREPARED BY: D. Deltenermeyer

DATE:	BY:	DESCRIPTION:

DETAIL

10

11 OF

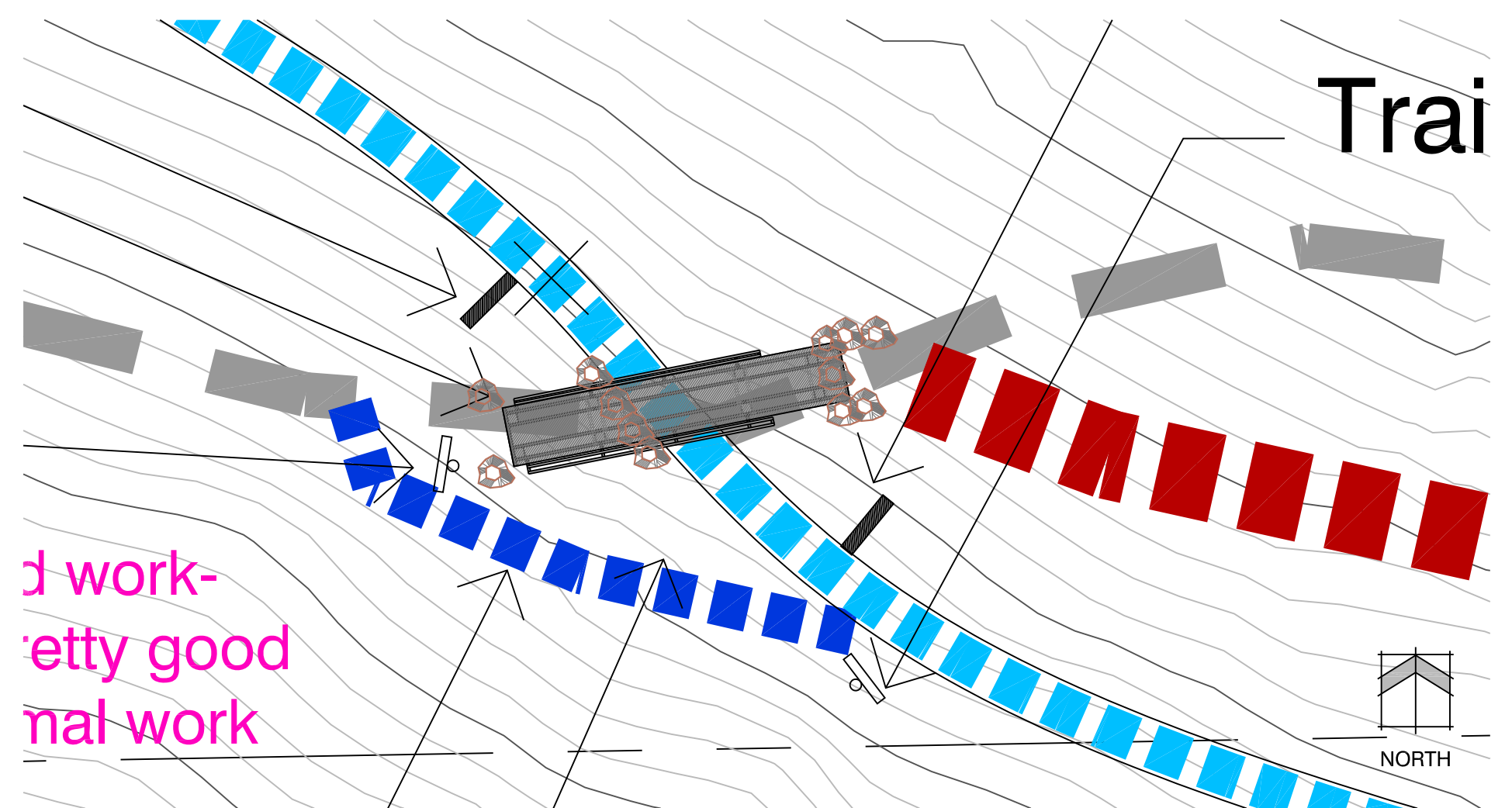

1
11 Grade Separated Crossing site plan
Not To Scale

SCALE 1" = 10'

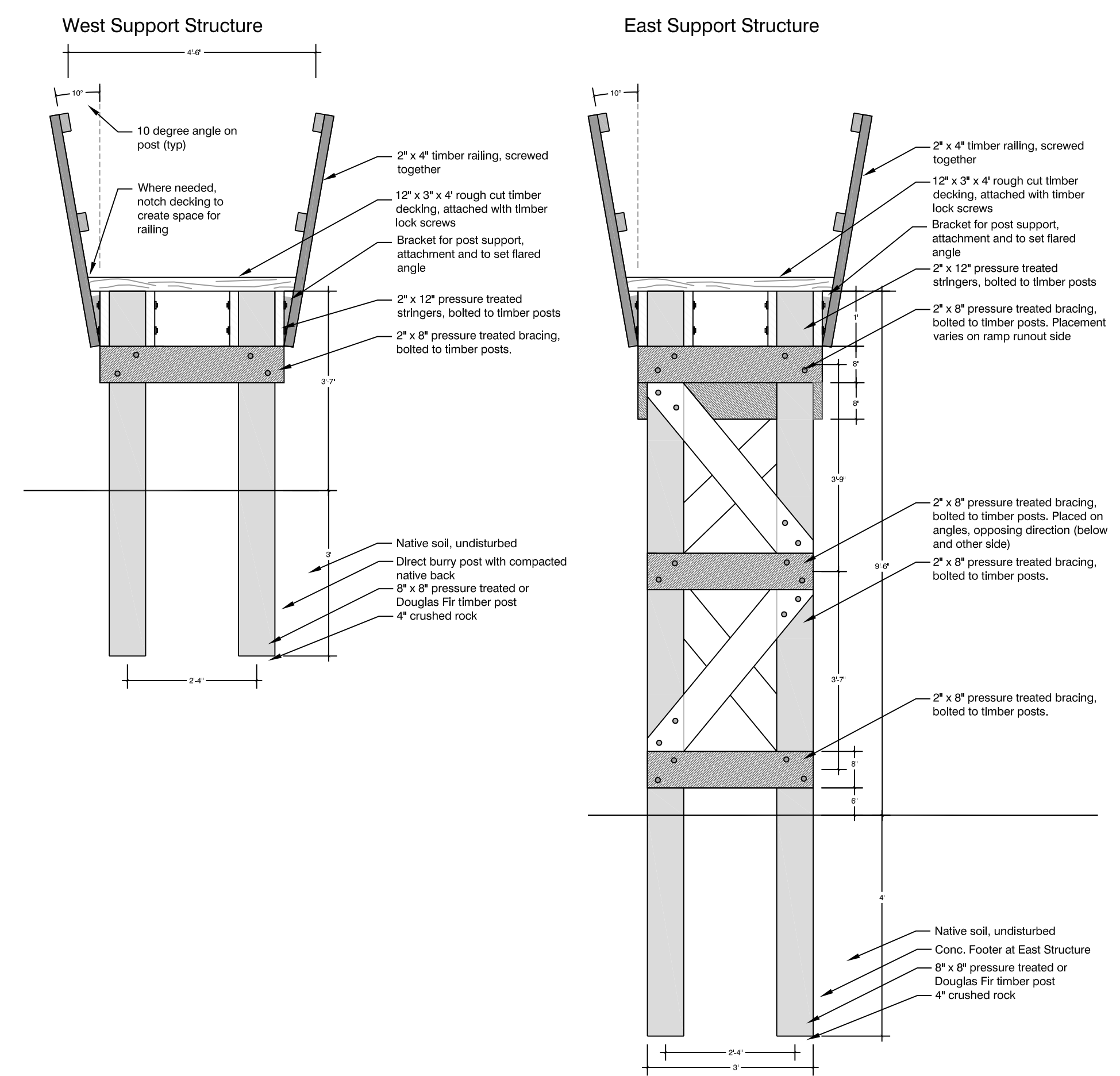

2
11 Timber Post Support Structure Detail
Not To Scale

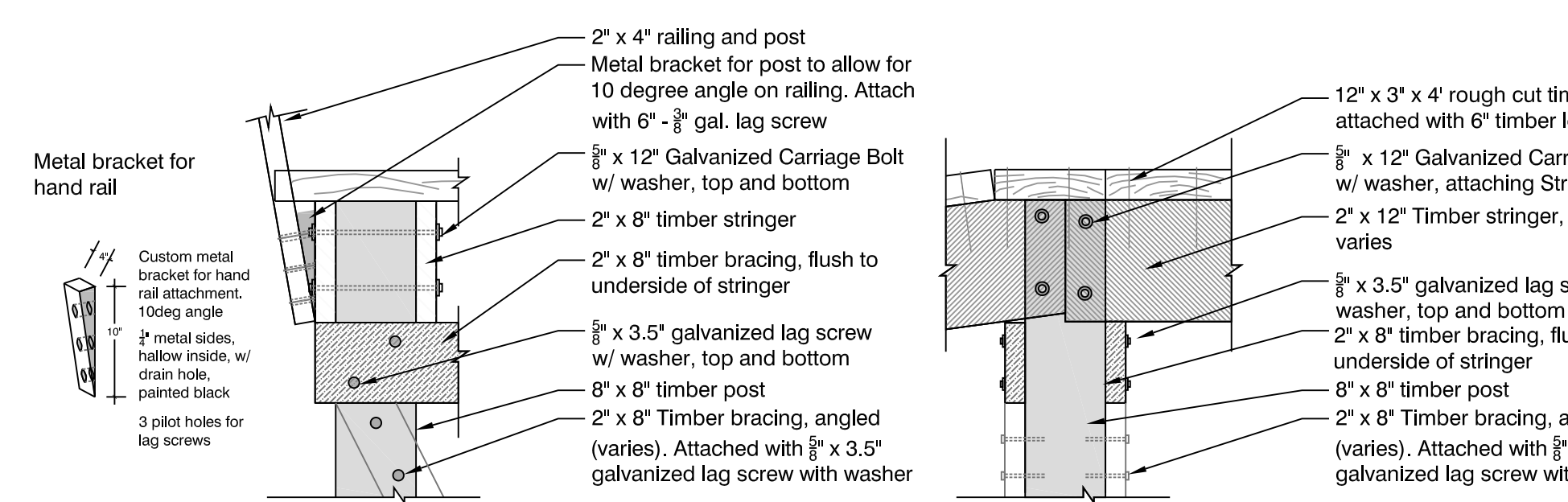

6
11 Attachment Details
Not To Scale

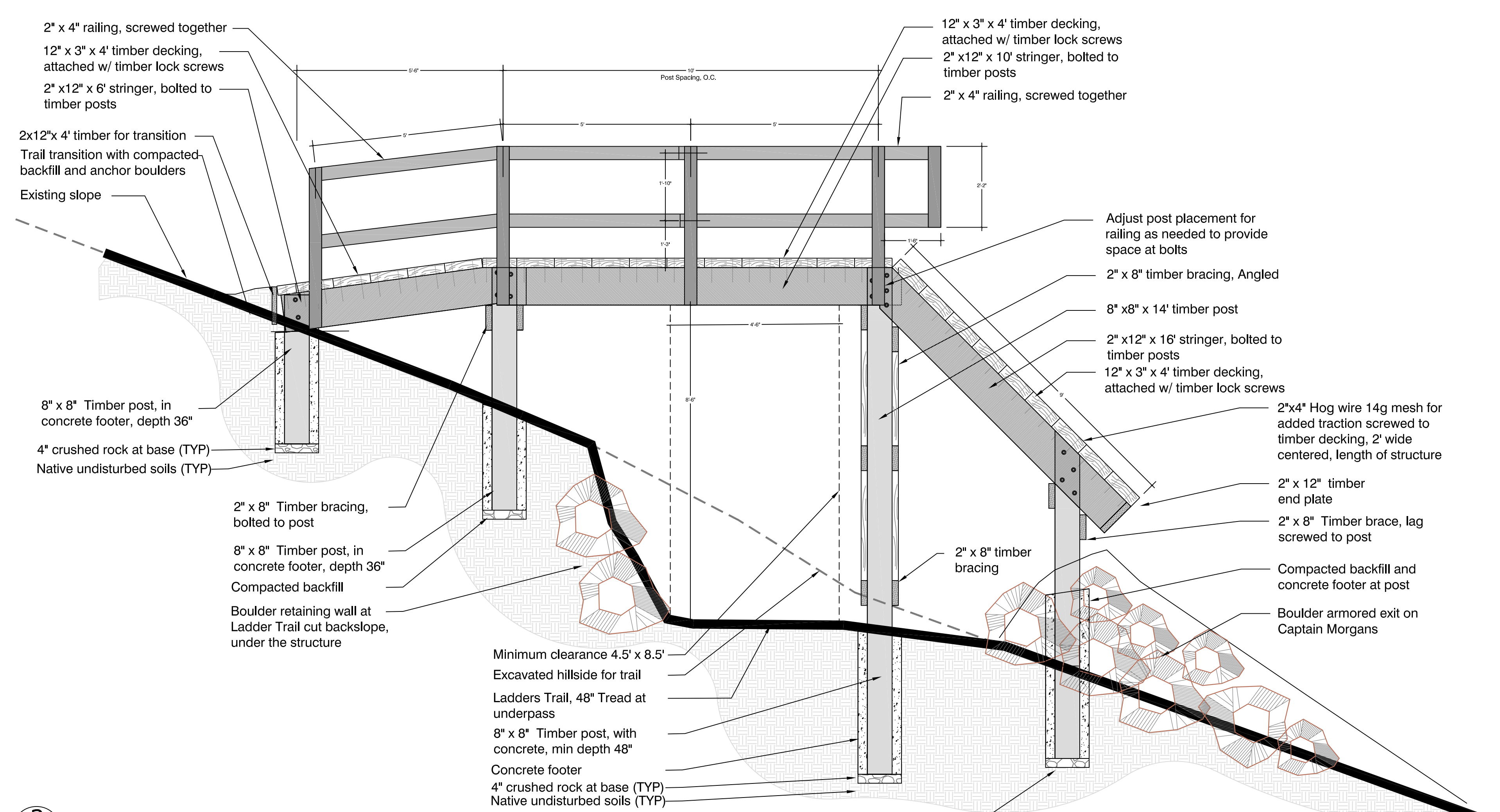

3
11 South Elevation Detail
Not To Scale

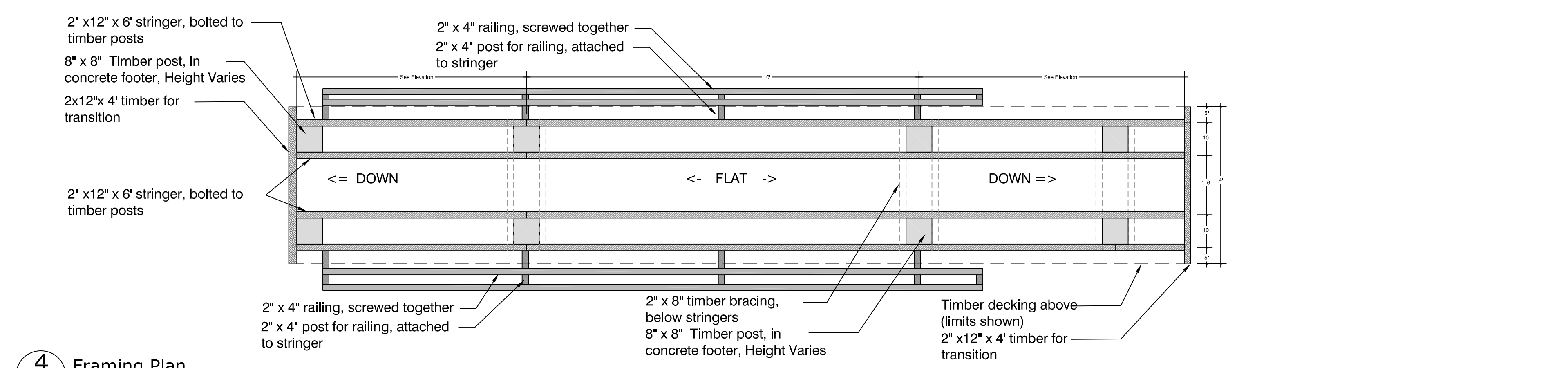

4
11 Framing Plan
Not To Scale

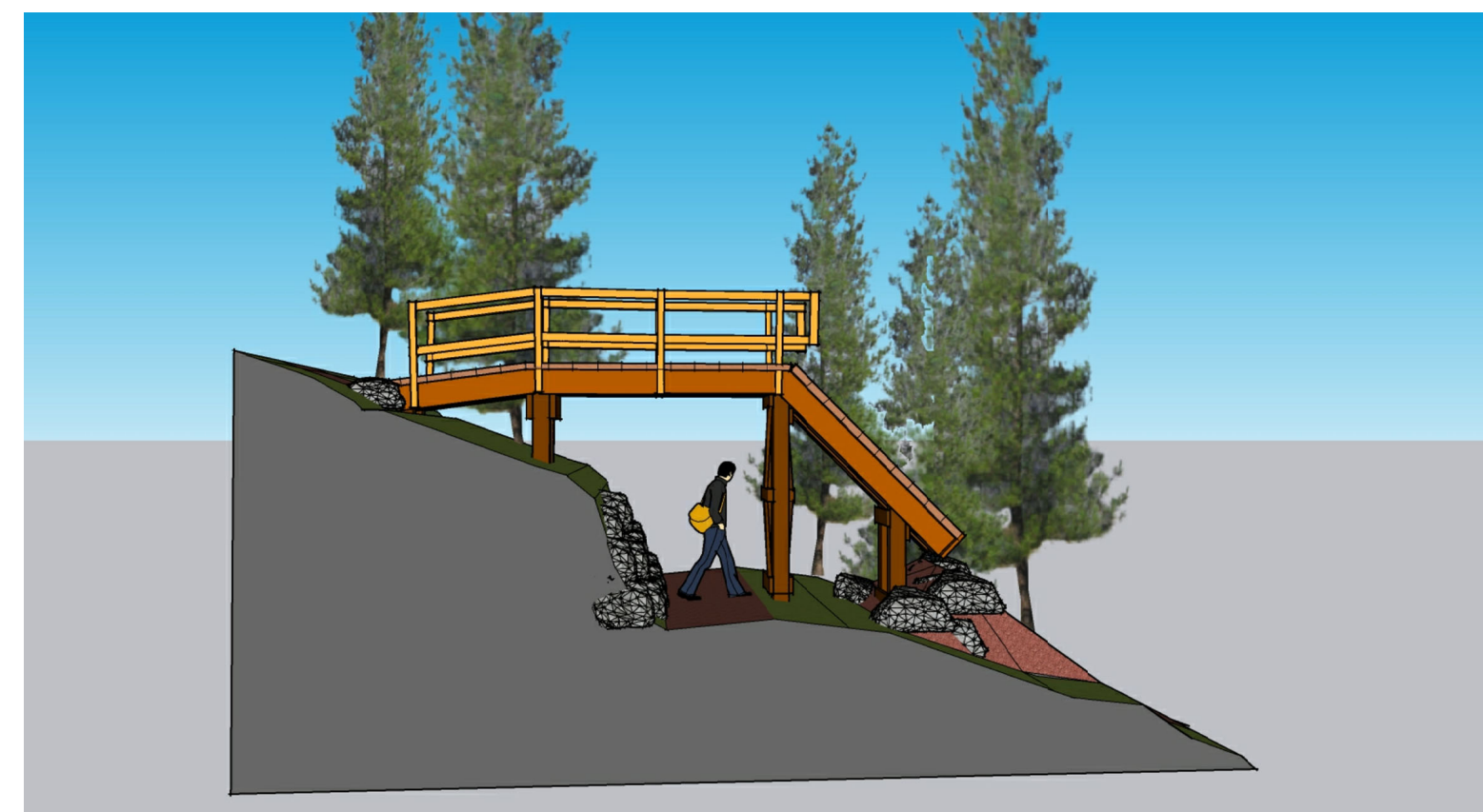

DATE:	BY:	DESCRIPTION:

A:\Design\Dev\Regional\Bucks\NorthCheyenneCañon\General Information\Trail Development\Ladders_Extension_base (file.dwg) [5:11_Details] 1/24/2024 3:46:22 PM ddeltmeyer

SCHEDULE F – SCOPE OF WORK

North Cheyenne Cañon Park Trail Development for the Ladders Trail

Overview

North Cheyenne Canon Park is a well-known and loved park on the southwest side of Colorado Springs. The park dates to the 1880s and is one of the oldest designated parks within Colorado Springs. In 2018 the North Cheyenne Canon Park Master and Management Plan were approved and adopted by the Parks, Recreation and Cultural Services Advisory Board. Since 2018 the Parks Department has begun numerous master plan implementation projects across the park.

The Ladders Trail is one such project the Parks Department is looking to implement within North Cheyenne Cañon Park. The new trail will provide a unique trail experience with stunning viewsheds, wilderness interactions and new non-motorized trail connectivity within the park. A trails' contractor is solicited to build this trail network deploying low-impact methods using hand-built and or/machine-built techniques to complete a finished trail.

Project Scope of Work

Work to be completed under this contract consists of furnishing all labor, materials, and equipment, to construct the natural surface trails identified within this request for proposal. The Ladders Trail includes several segments of trail connecting from Gold Camp Road/Chutes and existing Ladders Trail on the east to the Columbine Trail on the west end of the project. The trail is designated as non-motorized recreational trails open to hiking, mountain biking and equestrian use rated at an Intermediate skill level (Blue).

The Ladders Trail project consists of two Ladders Trail segments based on site conditions with similar side slope, vegetation, rock outcrops and other terrain.

Segment 1 Station 0+00 to 45+75

Segment 1 starts at east end of the trail at Gold Camp Road and concludes at Station 45+75, where the proposed trail crosses an existing social trail. This segment includes slightly more challenging build conditions than the remaining trail corridor, therefor it's been established as it on segment.

Segment 2 – Station 45+75 to 132+75

Segment 2 captures the remain trail corridor in its entirety. While some site specific locations may be slightly more challenging, the majority of the trail corridor have more "favorable" and "buildable" trail conditions.

The segments of trail corridors and specific sites are identified on the Project Map. The trails will be non-motorized recreational use on the multi-use trails and are anticipated with an approximated breakdown at 65% bikes, 34% hikers, <1% equestrian (limited because of site access and trailer parking constraints). Captain Jack Trail, which is one of the specific sites, is the only trail open to dirt bikes and non-motorized recreational use.

Based on trail connectivity options, improved access, and the trail serving as an alternative to Gold Camp Road, Parks anticipates the direction of traffic on the trails will likely be equal in both directions. Speed control for bikes, line of site and reduced user conflict will be critical. The scope of work for each segment follows below. Trail segments are identified on the map and the photo conditions images.

Drainage crossings, armoring, and timber cross veins are to be included on the costs of the trail tread construction. Additional specific site improvements are included as separate bid items to capture these scope of work efforts.

Segment 1 Gold Camp Road (east) Station 0+00 to Social Trail at 45+75

Objective: Provide a newly constructed flowing contour single track trail for non-motorized recreational use paralleling Gold Camp Road. The trail will have a rolling contour flowy trail feeling, with sporadic option lines of technical trail features off the main line.

Trail width: 36" min.

Average trail grade: 5% (5-10% trail tread range)

Difficulty: "Blue" rated multi-use, multi-directional for hikers, bikers and equestrians.

Trail corridor description: 4'w x 12'h. Vegetation on the north facing slopes (low to mid elevations) consists of light density coniferous forest with sporadic small pockets of thick growth new generation (2-6' tall) of Douglas fir. Intermixed into the canopy are small diameter (<12" DBH) standing dead. Overall trees range in size from 4" DBH to 18" DPB. Some larger old growth trees up to 30" DBH are present on the hillside. Some downfall exists in the area but can be moved or cut for a pass through. Downed timbers and felled trees shall be incorporated into the design to prevent trail short cutting in applicable places. The trail will look to incorporate existing large diameter trees into the sustainable design. The ground cover is mostly un-vegetated duff or spotty thin cover of grasses, sedges and small bushes and scree.

Hillside slope: Hillside consists of varying slopes ranging from 35-60%. Some minimal short sections may be greater or less than this range. Minimally, there is fractured bedrock exposed along areas of this hillside that may be encountered in short sections (up to 20 linear feet segments (not continuous rock). Larger boulders and field stones scattered in the area but are avoidable and/or integrated into the trail design. In some locations exposed and or cluster of larger bedrock boulders will be integrated into the trail design, allowing the trail to wind through adding to the trail character and user experience.

There are a few sections of the trail that cross scree fields. The finished trail bench shall be stable in this section and may be wider than the standard trail width and back slope may be steeper. Refer to the notes below for Trail Construction Debris Management.

Segment 2 – 45+75 to 135+75 Columbine Trail Intersection

Objective: Provide a newly constructed single track trail for non-motorized recreational use along Gold Camp Road, including a connecting spur to the Spring Creek Trail. The trail will have a rolling contour flowy trail feeling, with sporadic option lines of technical trail features off the main line.

Trail width: 36" min.

Average trail grade: 5% (5-10% trail tread range)

Difficulty: "Blue" rated multi-use, multi-directional for hikers, bikers and equestrians.

Trail Corridor: This area includes west, south and east facing aspects where the vegetation is a bit sparser with light density of ponderosa pines and Douglas firs, grassy slopes, Scrub Oak slopes, and non-vegetated slopes. The contractor shall maintain as much vegetation as possible to retain slope and soil stability. Downfall may be incorporated into the design and character of the trail.

Hillside slope: Hillside consists of varying slopes ranging from 20-40%. Some minimal short sections may be greater or less than this range. Along the eastern run of the trail there are some scattered small fieldstones (up to 15" diameter) and partially buried boulders or exposed rock

outcrops. The trail alignment integrates use of the boulders when appropriate otherwise avoid such boulders. Fieldstones become less common further west towards Gold Camp Road but some rock outcrops are still present. There are also some locations where there is minimal vegetation and scree slopes (much less challenging than found in segment 1).

Trail Construction Debris Management

Construction Debris and Rock Fall (from construction) hazard to Gold Camp Road from Trail Construction- The eastern segment of this trail traverses steep side slope with Gold Camp Road directly below in some locations. The Contract shall provide a rock fall reduction tactic to prevent rock, overburden and construction debris from falling to Gold Camp Road. For significant and high prone areas, the City will support closing Gold Camp Road to vehicular and recreation access for the safety of the public. While the entire trail corridor is subject to debris hazards, three levels of risk have been identified for consideration. The debris risks include Yellow for lower risk, Orange for elevated risk and Red for high risk. This is open for discussion and additional review. Safety will be a top priority so the contractor can provide input to this element.

Individual Site description Notes

Site 1 – Trail start Gold Camp Road East – This location will provide a connection to Gold Camp Road along a short section of hillside that is part of the Gold Camp Road prism (land bridge). To minimize the grading in this location, a boulder wall and fill material will be used to construction a partial bench trail (cut and fill trail bench). Boulders will be provided by the City of Colorado Springs on site, the contractor will be responsible for construction the wall and generating fill (from the site) to complete the bench. Contractor to add culvert near exit of Captain Morgans to convey flows under new trails coming off of Gold Camp Road. Contractor to install Telespare Post and sleeves for the trail crossing per the plan.

*Site 2 – Grade separated intersection **Ad Alt 1** – This location will include the timber grade separated structure. The contractor will prep the site as part of the trail work, including the over excavation of the trail back slope and spoils stockpile for future use. The Boulder wall will also be included in this location per the plan base bid. The timber structure will be included as Ad Alt 1. The Captain Morgans trail tie in (above and below) at the structure will be completed by volunteers, managed by the City of Colorado Springs.*

Site 3 – Scree Slope Mitigation – At Station 18+50 to 19+50 is an area where the trail crosses and extensive scree slope, directly above Gold Ramp Road. This section will need to be constructed to minimizes post-construction rock/scree fall. Above and beyond the trail construction, the contractor shall spread soil amendment in the first 10' below the trail critical edge and install seed and an erosion control blanket to help stabilize scree movement. The City of Colorado Springs will provide seed, contractor to be responsible for installing the amendment and erosion control blanket (2SC-PN8 70% Straw / 30% Coconut- (Severe slopes/Heavy Run-Off available from C and C Sand and Stone) and bio-degradable stakes. Ad Alt 2 includes additional measures with the placement of a Geoweb Slope protection anchored under the trail tread.

Site 4 – Penrose Trail adjustment and crossing improvements – At this new trail crossing, the new Ladders Trail will align with and use a short section of existing Penrose Trail. This will require the reroute of approximately 330 LF of Penrose Trail and existing trail closure. The reconfiguration will improve the trail intersection flow and line of sight.

Site 5 - Captain Jacks Trail Adjustment and crossing improvements – This new intersection will require a small reroute to the Captain Jacks Trail to improve the intersection visibility and crossing safety. The location also included rock armoring on a drainage crossing of Captain Jacks and a culvert installation on the Ladders Trail. Boulders to be added on the Ladders Trails to create

choke points. This will demonstrate a difference in trail character between the Ladders Trail (Multi-use) and Captain Jacks (Multi-use and MOTO use) and add speed control.

Site 6 - Spring Creek Trail Connector – Contractor to establish an improved connection from the new Ladders Trail to the existing Spring Creek Trail. The connector trail will include a short reroute with existing trail closures and improvements to the existing social trail and improvements to the intersection with the Spring Creek Trail.

Site 7 – Gold Camp Road Crossing (west) drainage – Improvements to the roadway drainage are necessary for the new trail to cross over the swale. The contractor to improve the roadside ditch and leading drainage swale, place rip rap, provide and install a culvert and enhance the crossing of Gold Camp Road. Contractor to install Telespar Post and sleeves for the trail crossing per the plan.

Wayfinding Post Installation

The scope of work includes contractor installation of three types of wayfinding posts along the trail corridor. All posts will be provided by the City to the contractor, for contractor installation. The posts include a 6" x 6" composite plastic posts installed to a depth of 36", a fiberglass carsointe posts installed to a depth of 20", and a metal telepar posts installed to a depth of 24". All posts to be level and installed per details. Locations to be coordinated with the City.

Trail Classification Specifications and Descriptions

Trail Rating

Per the North Cheyenne Cañon Park Master Plan the designation of the BLUE trails are assigned the following technical guidelines:

BLUE – Intermediate Trail: Trails may be narrower than the green trails and may have frequent challenges. Qualifiers – obstacles that demonstrate the level of difficulty that will be encountered along the trail segment and consistent with the blue designation – should be designed into the trails at every connection. Blue trails require attentiveness to negotiate. This includes sustained slopes ranging from 0-10%. Grades should not exceed 10% except for short distances up to 12%. Typical trail width is 18" to 36". Variable trail surface with occasional obstacles including steps, water diversions, dips, roots and rocks. The trail corridor shall be 4' wide and 12' high.

The following are descriptions of trail features that are likely to be included with the trail construction and are to be considered incidental costs to the trail construction.

Basic Trail Construction

Basic trail construction consists of standard full bench trail construction with appropriately placed grade reversals and drainage dips. The overwhelming majority of the trail construction is simple basic trail in native soil. Constructed trail structures may include retaining walls, climbing turns, rock armoring, drainage features and steps. These structures are considered integral to trail construction and not a separate pay item.

Trail Bench with Constructed Fill

Basic trail construction with the trail tread being created from the excavated fill. This technique will solely be used for locations where the trail will be cross below larger diameter trees the City desires to remain (less than 5 occurrences). This technique would minimize impact to the existing tree roots by providing fill over the tree roots with the new trail. Fill to be generated from the newly excavated trail below and/or above the fill section. This technique may also be used in other locations as coordinated between the contractor and the City.

Trails Over Rocks or through rocky sections

Several larger rocks that are manageable to relocate may exist along the trail corridor that needs to be adjusted or moved. Remove only enough existing rock to clear the tread as necessary. Make sure existing rocks/boulders within the trail tread are stable. Fill voids between the boulders within the trail tread with small native stone and gravel. Where applicable, some trail “paving” may be accomplished with large flat rocks on the trail tread. In some locations, the trail will be on top of non-movable exposed bedrock or buried boulders. In a few locations, less than a total of 250 linear feet for the entire project there may be a larger boulder or fractured loose bedrock that may be “chiseled” or broken away to create a more appropriate trail tread.

Where the trail interacts with notable boulders and rock outcrops, Parks would like to seek opportunities for the contractor to create an option line for mountain bike use over the technical feature. This line can be formal or informal and suggestive providing an opportunity for users to “burn in” the line. Some locations have more notable boulders that could be integrated as a technical optional feature. Option lines will be more specific for a feature as opposed to a parallel option line running more than 15 feet or more. This will be value-added to the project and aid in developing an exceptional trail user experience with the unique landscape of the project area.

Note: All rocks must be set in place with a minimum of three points of contact. When finished, the trail tread should be level or slightly elevated above the surrounding grade to prevent snow from drifting into the tread. Keep in mind that our primary goals are to delineate a route and to construct a safe stable trail tread.

Paved Swale Crossings (trail armoring)

Across high flow drainage swales with notable recent water flow shall require rock pavers installed for trail tread armoring and critical edge reinforcement. To ensure the safest crossing possible, all pavers need to have a smooth top. The critical edge of the trail shall be armored with large rocks or a mono wall for added protection. Paved crossings are anticipated 3’ wide x 4’ long unless field conditions require differently. Note, there are no perennial drainages that trail will cross. There are Eight estimated armored crossings on the Ladders Trail. Note this does not include the Timber Cross Veins sites (see below).

Rock Walls

Rock walls may be necessary in key locations of the project depending on the field fit of the trail. Existing boulders tied into new walls shall be stable before constructing the wall. These walls need to be both aesthetically pleasing and functional. Backfill the walls with existing soil to create a trail tread above the wall. All wall rocks will be set using a minimum of three points of contact to ensure stability. Walls shall not exceed 30” in height. For aesthetic consistency, use rocks larger than 12” long x 6” height x 6” depth and smaller than 24” long x 24” height and 24” depth. All rock will come from the site (abundant supply in the project area); it is not anticipated that the Contractor will need to import rock.

Drainage Work

Timber cross veins shall be constructed in large intermittent drainages with recent notable evidence of water flow and channel cutting/incising to control the channel slope and stability as well as hold the trail grade. These locations are marked in the plans. This coincides with the placement of armored trail crossing in drainages with evidence of recent flow. There are Seven estimated crossings with timber cross veins on the Ladders Trail.

Timber cross veins shall be constructed of felled timbers from on site (trees to be approved by project manager). The timbers shall be approximately 10-12” diameter limbed timbers at 6’ in length. The two timbers set at approximately at a 60 degree opening with the point pointing up the drainage. Timber ends on the outside shall be anchored/trenched in the side slope of the

drainage channel. Logs are set level and are to be backfilled. The timber cross veins are to be two rows tall. At each crossing, there shall be one timber cross vein below the new trail and above the new trail, within the drainage. All timbers to be secured with three #4 rebar, 24" long in each timber to secure in the ground or wood stakes created from on-site material.

Trail Closure

There are several sections of social trails in the project area to be closed. Most of the social trails are small, narrow usually created from foot and bike traffic. They will require minimal closure.

Trail closure by the contractor will be required at each of the new trails' crossing of the old trails in the area. Trail closure prioritization will focus key locations and consists of de-compacting existing trail tread, removing the visible trail bench (re-establish natural slope), disrupting fall line drainage on the tread and obscuring the old trail by placing vegetation and/or rocks at random locations within the closed tread. Select trees, approved by City staff, may be felled and laid across the trail closure in key areas.

Its anticipated closure will consist of old trail closure of 50' long as measure from the new trail, in all directions, unless otherwise noted.

Upturned Roots, downed trees and hazard trees. Upturned roots and downed trees will be left near or in the trail corridor. Remove only enough material to allow passage without distorting the natural aesthetics of the landscape. Remove all "widow makers" and hazard trees that could impact trail users' safety. The contractor shall remove hazard trees that are likely to fall onto the trail within 3 years and pose a safety concern during construction. Any uphill side trees impacted (under cut, roots cut, or native soil removed around root mass) by trail building shall be removed during construction.

Additional Project Notes

Permitting

No permits area anticipated for this project.

Access to project site

The project area is located along Gold Camp Road in North Cheyenne Canon Park. There are several entrance and exit points to this trail corridor. It is recommended that Segment 1 be constructed during non-busy season (May to Sept), as to limit the public closures of Gold Camp Road and limit impacts to visitor. Parks will be open to contractor's suggestions on sequency.

Equipment can be staged along the trail at the risk of the Contractor. While this new trail will be closed for the work, the park will remain open for recreational use. Trail work warning signs, trail closure signs and caution tape shall be utilized by the contractor as appropriate to protect the public. This will be the responsibility of the contractor. North Cheyenne Canon Roadway and Gold Camp Road closes nightly from 10 pm to 5 am, with security gates.

Trail Flagging and Staking

The trail corridor was previously flagged this summer. The Parks Department will provide a PDF of the trail alignment, as well as a KMZ file that can be uploaded into Google Earth or downloaded into a GPS device. The trail alignment is subject to slight modifications before construction, based on bird surveys and final archeological survey. The awarded contractor shall be consulted of any changes and if there are any price changes.

If the Contractor wishes the Parks Department to complete additional marking or staking throughout the entire trail corridor that will occur before the Contractor commencing work. It is not anticipated that the Parks Department will flag the critical edge with sprinkler flags. The Parks Department will coordinate with the selected Contractor to field-fit specific trail features/structures and alternative lines.

The contractor has approximately an eight (8') foot buffer around the flags. Please be observant to trail grades should the alignment deviated from the flagline. If the Contractor needs to align the trail outside this eight (8') buffer, they must consult with the Parks Department. Contractor to determine how they will construct, including but not limited to, steep cross slope, small drainage crossings with rocks, trail over rock fields, and climbing turns. Machinery can be utilized for the construction of the trail, such as a Sweco, Ditch Witch or Perntamoter Ibex or others, however, the wheelbase cannot exceed three feet.

The City of Colorado Springs relies on the trail construction practices of Volunteers for Outdoors Colorado (VOC) and International Mountain Bicycling Association for trail standards. Please refer to *Volunteers for Outdoor Colorado, Crew Leader Manual*, *Trail Solutions: IMBA's Guide to Building Sweet Singletrack*, and *BIKE PARKS: IMBA's guide to new school trails*, as references for trail design.

Project Meetings

Once the Contractor has been issued a Notice to Proceed, the Parks Department will hold a meeting with the Contractor to review the design intent, the project schedule, and answer any outstanding questions.

Weekly Construction Meetings

Once the trail is under construction, the City will require weekly construction meetings to be able to answer any questions and provide additional information, if needed. The Parks Department representative can be available if the Contractor has additional questions and needs on-site clarifications between the weekly meetings.

All bids provided should highly consider Parks' low maintenance operation requirements.

Specifications, Details and References

The City of Colorado Springs, Parks, Recreation and Cultural Services Department (Parks Department) relies on the trail construction practices of International Mountain Bicycling Association and Volunteers for Outdoors Colorado (VOC) for trail standards. Please refer to *Trail Solutions: IMBA's Guide to Building Sweet Singletrack* and *Volunteers for Outdoor Colorado, Crew Leader Manual*, as references for trail design.

Additional design guidelines have been established in the adopted North Cheyenne Cañon Master Plan available on the City's website at:

https://coloradosprings.gov/sites/default/files/inline-images/18.07.02_ncc_master_and_management_plan.pdf

Contractor Requirements

The contractor shall have significant demonstrated experience building natural surface trails. Additional desired qualifications include:

- Experience on and in similar terrain
- Experience with similar size and scale of projects
- Familiarity with local/regional landscape
- Membership in good standing with Professional Trail Builders Association or strongly demonstrated experience equal to PTBA qualifications.

SCHEDULE G – EXHIBITS

- Exhibit 1 Sample Contract
- Exhibit 2 Minimum Insurance Requirements
- Exhibit 3 Qualification Statement
- Exhibit 4 Bid Certification and Representations and Certifications
- Exhibit 5 Bid Bond

EXHIBIT 1 – SAMPLE CONTRACT

CONSTRUCTION CONTRACT

Contract Number:		Project Name/Title	
Vendor/Contractor			
Contact Name:		Telephone:	
Email Address:			
Address:			
Federal Tax ID #		Please check one:	<input type="checkbox"/> Corporation <input type="checkbox"/> Individual <input type="checkbox"/> Partnership
City Contracting Specialist		City Dept Rep	
NOT TO EXCEED Contract Amount:		City Account #	
Contract Type:	Fixed Unit Price	Period of Performance:	

1. INTRODUCTION

THIS Fixed Unit Price CONTRACT ("Contract") is made and entered into this XXX day of XXX, 2024 by and between the City of Colorado Springs, a Colorado municipal corporation and home rule city, in the County of El Paso, State of Colorado, (the "City"), and _____ (the "Contractor").

THE CITY AND THE CONTRACTOR HEREBY AGREE AS FOLLOWS:

The City has heretofore prepared the necessary Contract Documents for the following Activity: XXXX.

The Contractor did on the XXX day of XXX, 2024 submit to the City the Contractor's written offer and proposal to do the work therein described under the terms and conditions therein set forth and furnish all materials, supplies, labor, services, transportation, tools, equipment, and parts for said work in strict conformity with the accompanying Contract Documents, which are attached hereto and incorporated herein by this reference, including the following:

1. This Contract
2. Schedule A – Price Sheet
3. Schedule B – General Construction Terms and Conditions
4. Schedule C – Special Contract Terms and Conditions
5. Schedule D – General Specifications
6. Schedule E – Special and Technical Specifications
7. Schedule F – Scope of Work
8. Exhibit 1 – Performance, Labor and Material Payment, and Maintenance Bonds
9. Exhibit 2 – Minimum Insurance Requirements

2. COMPENSATION/CONSIDERATION

THIS FIXED UNIT PRICE CONTRACT is established at the Not to Exceed amount of \$xxxxxxx.

Subject to the terms and conditions of the Contract Documents, Contractor agrees to furnish all materials and to perform all work as set forth in its proposal and as required by the Contract Documents.

All pricing is in accordance with the fixed unit prices found in Schedule A, as proposed by the Contractor. Payment made for actual quantities as set forth in Schedule B, General Construction Terms and Conditions. At no time shall the total obligation of the City exceed the not to exceed amount of this Contract.

3. TERM OF CONTRACT

Contractor will start work promptly after the Notice to Proceed and continue to work diligently until completed. The Contractor shall complete all work on an as ordered basis throughout the Contract period which is **the date of Notice to Proceed through April 30, 2024** ("Period of Performance") as per the specifications and drawings. The Contractor shall provide a two-year guarantee on all work performed under this Contract after the job has been completed and accepted.

4. INSURANCE

The Contractor shall provide and maintain acceptable Insurance Policy(s) consistent with the Minimum Insurance Requirements attached as Exhibit 2, which includes Property, Liability, and as otherwise listed in Exhibit 2. The City of Colorado Springs shall be reflected as an additional insured on the Property and Liability policy(s).

Further, Contractor understands and agrees that Contractor shall have no right of coverage under any existing or future City comprehensive, self, or personal injury policies. Contractor shall provide insurance coverage for and on behalf of Contractor that will sufficiently protect Contractor, or Contractor's agents, employees, servants or other personnel, in connection with the services which are to be provided by Contractor pursuant to this Contract, including protection from claims for bodily injury, death, property damage, and lost income. Contractor shall provide worker's compensation insurance coverage for Contractor and all Contractor personnel. Contractor shall file applicable insurance certificates with the City and shall also provide additional insurance as indicated in this Contract. ***A CURRENT CERTIFICATE OF INSURANCE IS REQUIRED PRIOR TO COMMENCEMENT OF SERVICES LISTING THE CITY AND XXXX AS ADDITIONALLY INSURED.***

5. RESPONSIBILITY OF THE CONTRACTOR

- A. The Contractor shall be responsible for the professional quality, technical accuracy, and the coordination of all Scope of Work services furnished by the Contractor under this Contract. The Contractor shall, without additional compensation, correct or revise any errors or deficiencies in services provided under this Contract to the satisfaction of the City.
- B. The City's review, approval of, acceptance of, or payment for the services required under this Contract shall not be construed to operate as a waiver of any rights under this Contract or of any cause of action arising out of the performance of this Contract, and the Contractor shall be and remain liable to the City for any and all damages to the City caused by the Contractor's negligent performance of any of the services furnished under this Contract.

- C. The rights and remedies of the City provided for under this Contract are in addition to any other rights and remedies provided by law.
- D. If the Contractor is comprised of more than one legal entity, each such entity shall be jointly and severally liable hereunder.

6. WORK OVERSIGHT

- A. The extent and character of the work to be done by the Contractor shall be subject to the general approval of the City's delegated Project Manager.
- B. If any of the work or services being performed does not conform with Contract requirements, the City may require the Contractor to perform the work or services again in conformity with Contract requirements, at no increase in Contract amount. When defects in work or services cannot be corrected by re-performance, the City may (1) require the Contractor to take necessary action to ensure that future performance conforms to Contract requirements and (2) reduce the Contract price to reflect the reduced value of the work or services performed.
- C. If the Contractor fails to promptly perform the defective work or services again or to take the necessary action to ensure future performance is in conformity with Contract requirements, the City may (1) by Contract or otherwise, perform the services and charge to the Contractor any cost incurred by the City that is directly related to the performance of such work or service or (2) terminate the Contract for breach of contract.

7. SUBCONTRACTORS, ASSOCIATES, AND OTHER CONTRACTORS

- A. Any subcontractor, outside associates, or other contractors used by the Contractor in connection with Contractor's work under this Contract shall be limited to individuals or firms that are specifically identified by the Contractor in the Contractor's proposal and agreed to by the City. The Contractor shall obtain the City's Project Manager's written consent before making any substitution of these subcontractors, associates, or other contractors.
- B. The Contractor shall include a flow down clause in all of its subcontracts, agreements with outside associates, and agreements with other contractors. The flow down clause shall cause all of the terms and conditions of this Contract, including all of the applicable parts of the Contract Documents, to be incorporated into all subcontracts, agreements with outside associates, and agreements with other contractors. The flow down clause shall provide clearly that there is no privity of contract between the City and the Contractor's subcontractors, outside associates, and other contractors.

8. KEY PERSONNEL

The key personnel listed in the proposal and/or below will be the individuals used in the performance of the work. If any of the listed key personnel leave employment or are otherwise not utilized in the performance of the work, approval to substitute must be obtained by the Contractor from the City's Project Manager. Any substitute shall have the same or a higher standard of qualifications that the key personnel possessed at the time of Contract award.

9. START AND CONTINUANCE OF WORK

It is further agreed that the Contractor will start work promptly and continue to work diligently until this Contract is completed.

10. APPROPRIATION OF FUNDS

This Contract is expressly made subject to the limitations of the Colorado Constitution and Section 7-60 of the Charter of the City of Colorado Springs. Nothing herein shall constitute, nor be deemed to constitute, the creation of a debt or multi-year fiscal obligation or an obligation of future appropriations by the City Council of Colorado Springs, contrary to Article X, § 20, Colo. Const., or any other constitutional, statutory, or charter debt limitation. Notwithstanding any other provision of this Contract, with respect to any financial obligation of the City which may arise under this Agreement in any fiscal year after the year of execution, in the event the budget or other means of appropriation for any such year fails to provide funds in sufficient amounts to discharge such obligation, such failure (i) shall act to terminate this Contract at such time as the then-existing and available appropriations are depleted, and (ii) neither such failure nor termination shall constitute a default or breach of this Contract, including any sub-agreement, attachment, schedule, or exhibit thereto, by the City. As used herein, the term "appropriation" shall mean and include the due adoption of an appropriation ordinance and budget and the approval of a Budget Detail Report (Resource Allocations) which contains an allocation of sufficient funds for the performance of fiscal obligations arising under this Contract.

11. CHANGES

The Contractor and the City agree and acknowledge as a part of this Contract that no change order or other form or order or directive may be issued by the City which requires additional compensable work to be performed, which work causes the aggregate amount payable under the Contract to exceed the amount appropriated for this Contract as listed above, unless the Contractor has been given a written assurance by the City that lawful appropriations to cover the costs of the additional work have been made or unless such work is covered under a remedy-granting provision of this Contract. The Contractor and the City further agree and acknowledge as a part of this Contract that no change order or other form or order or directive which requires additional compensable work to be performed under this Contract shall be issued by the City unless funds are available to pay such additional costs, and, regardless of any remedy-granting provision included within this Contract, the Contractor shall not be entitled to any additional compensation for any change which increases or decreases the Contract completion date, or for any additional compensable work performed under this Contract, and expressly waives any rights to additional compensation, whether by law or equity, unless, prior to commencing the additional work, the Contractor is given a written change order describing the change in Contract completion date or the additional compensable work to be performed, and setting forth the amount of compensation to be paid, and such change order is signed by the authorized City representative, as defined below. The amount of compensation to be paid, if any, shall be deemed to cover any and all additional, direct, indirect or other cost or expense or profit of the Contractor whatsoever. It is the Contractor's sole responsibility to know, determine, and ascertain the authority of the City representative signing any change order under this Contract.

No change, amendment, or modification to this Contract shall be valid unless duly approved and issued in writing by the City of Colorado Springs Procurement Services Division. The City shall not be liable for any costs incurred by the Contractor resulting from work performed for changes not issued in writing by the City of Colorado Springs Procurement Services Division.

The following personnel are authorized to sign changes, amendments, or modifications to this Contract.

The Project Manager: Changes up to \$14,999.99

The City of Colorado Springs Chief of Staff: Changes up to \$499,999.99

The Mayor of the City of Colorado Springs: Unlimited

12. ECONOMIC PRICE ADJUSTMENT

- A. The Contractor shall notify the City of Colorado Springs Procurement Services Division if, at any time during contract performance, the rate of pay for labor or the unit prices for material shown in Schedule A experiences a significant increase. A change in price shall be considered significant when the unit price of an item increases by 10% from the execution date of this Contract. The Contractor shall furnish notice of this increase within 60 days after the increase, or within any additional period that the City Procurement Services Division may approve in writing, but not later than the date of final payment under this Contract. The notice shall include the Contractor's proposal for an adjustment in the Contract unit prices to be negotiated under paragraph (b) of this clause, and shall include, in the form required by the City Procurement Services Division, supporting data explaining the cause, effective date, and amount of the increase and the amount of the Contractor's adjustment proposal.
- B. Promptly after the City Procurement Services Division receives the notice and data under paragraph (a) of this clause, the City Procurement Services Division and the Contractor shall negotiate a price adjustment in the contract unit prices and its effective date. However, the City Procurement Services Division may postpone the negotiations until an accumulation of increases in the labor rates (including fringe benefits) and unit prices of material shown in Schedule A results in an adjustment allowable under paragraph (c)(3) of this clause. The City Procurement Services Division shall modify this contract (1) to include the price adjustment and its effective date and (2) to revise the labor rates (including fringe benefits) or unit prices of material as shown in Schedule A to reflect the increases resulting from the adjustment. The Contractor shall continue performance at current rates pending agreement on, or determination of, any adjustment and its effective date.
- C. Any price adjustment under this clause is subject to the following limitations:
1. Any adjustment shall be limited to the effect on unit prices of the increases in the rates of pay for labor (including fringe benefits) or unit prices for material shown in Schedule A. There shall be no adjustment for:
 - (i) Supplies or services for which the production cost is not affected by such changes;
 - (ii) Changes in rates or unit prices other than those shown in Schedule A; or
 - (iii) Changes in the quantities of labor or material used from those shown in Schedule A for each item.
 2. No upward adjustment shall apply to supplies or services that are required to be delivered or performed before the effective date of the adjustment, unless the Contractor's failure to deliver or perform according to the delivery schedule results from causes beyond the Contractor's control and without its fault or negligence, within the meaning of the Default clause.
 3. There shall be no adjustment for any change in rates of pay for labor (including fringe benefits) or unit prices for material which would not result in a net change of at least 3 percent of the then-current total contract price. This limitation shall not apply, however, if, after final delivery of all line items, either party requests an adjustment under paragraph (b) of this clause.

4. The aggregate of the increases in any contract unit price made under this clause shall not exceed 10 percent of the original unit price.

13. ASSIGNMENT

No assignment or transfer by the Contractor of this Contract or any part thereof or of the funds to be received thereunder by the Contractor will be recognized unless such assignment has had the prior written approval of the City and the surety has been given due notice of such assignment. Such written approval by the City shall not relieve the Contractor of the obligations under the terms of this Contract. In addition to the usual recitals in assignment contracts, the following language must be included in the assignment:

It is agreed that the funds to be paid to the assignee under this assignment are subject to a prior lien for services rendered or materials supplied for the performance of the work called for in said contract in favor of all persons, firms, or corporations rendering such services or supplying such materials.

14. CHOICE OF LAW

This Contract is subject to and shall be interpreted under the law of the State of Colorado, and the Charter, City Code, Ordinances, Rules and Regulations of the City of Colorado Springs, Colorado, a Colorado home rule city. Court venue and jurisdiction shall be exclusively in the Colorado District Court for El Paso County, Colorado. The Parties agree that the place of performance for this Contract is deemed to be in the City of Colorado Springs, El Paso County, State of Colorado. The Contractor shall ensure that the Contractor and the Contractor's employees, agents, officers and subcontractors are familiar with, and comply with, applicable Federal, State, and Local laws and regulations as now written or hereafter amended.

15. WORKERS' COMPENSATION INSURANCE

Contractor shall take out and maintain during the Period of Performance, Colorado Worker's Compensation Insurance for the Contractor and all employees of the Contractor. If any service is sublet by the Contractor, the Contractor shall require the subcontractor to provide the same coverage for the subcontractor and subcontractor's employees. Workers' Compensation Insurance shall include occupational disease provisions covering any obligations of the Contractor in accord with the provisions of the Workers' Compensation Act of Colorado.

16. INDEMNIFICATION

Contractor agrees that the Contractor shall indemnify, defend and hold harmless the City, its officers, employees and agents, from and against any and all loss, damage, injuries, claims, cause or causes of action, or any liability whatsoever resulting from, or arising out of, or in connection with the Contractor's obligations or actions under this Contract caused by any willful or negligent error, omission or act or a failure to observe any applicable standard of care by the Contractor or any person employed by it or anyone for whose acts the Contractor is legally liable. In consideration of the award of this Contract, to the extent damages are covered by insurance, the Contractor agrees to waive all rights of subrogation against the City, its subsidiary, parent, associated and/or affiliated entities, successors, or assigns, its elected officials, trustees, employees, agents, and volunteers for losses arising from the work performed by the Contractor for the City. The indemnification obligation shall survive the expiration or termination of this Contract

17. INDEPENDENT CONTRACTOR

In the performance of the Contractor's obligations under this Contract, it is understood, acknowledged and agreed between the parties that the Contractor is at all times acting and performing as an independent contractor, and the City shall neither have nor exercise any control or direction over the manner and means by which the Contractor performs the Contractor's obligations under this Contract, except as otherwise stated within the Contract terms. The City shall not provide any direction to the Contractor on the work necessary to complete the project. Contractor understands that it is an independent contractor responsible for knowing how to perform all work or tasks necessary to complete project. The Contractor understands and agrees that the Contractor and the Contractor's employees, agents, servants, or other personnel are not City employees. The Contractor shall be solely responsible for payment of salaries, wages, payroll taxes, unemployment benefits or any other form of compensation or benefit to the Contractor or any of the Contractor's employees, agents, servants or other personnel performing services or work under this Contract, whether it is of a direct or indirect nature. Further in that regard, it is expressly understood and agreed that for such purposes neither the Contractor nor the Contractor's employees, agents, servants or other personnel shall be entitled to any City payroll, insurance, unemployment, worker's compensation, retirement or any other benefits whatsoever.

18. APPLICABLE LAW AND LICENSES

In the conduct of the services or work contemplated in this Contract, the Contractor shall ensure that the Contractor and all subcontractors comply with all applicable state, federal and City and local law, rules and regulations, technical standards or specifications. The Contractor shall qualify for and obtain any required licenses prior to commencement of work.

19. PRIOR AGREEMENTS

This is a completely integrated Contract and contains the entire agreement between the parties. Any prior written or oral agreements or representations regarding this Contract shall be of no effect and shall not be binding on the City. This Contract may only be amended in writing, and executed by duly authorized representatives of the parties hereto.

20. INTELLECTUAL PROPERTY

The Parties hereby agree, and acknowledge, that all products, items writings, designs, models, examples, or other work product of the Contractor produced pursuant to this Contract are works made for hire, and that the City owns, has, and possesses any and all ownership rights and interests to any work products of the Contractor made under this Contract, including any and all copyright, trademark, or patent rights, and that compensation to the Contractor for Agreement and acknowledgment of this intellectual property right section of this Contract is included in any compensation or price whatsoever paid to the Contractor under this Contract. It is the intent of the parties that the City shall have full ownership and control of the Contractor's work products produced pursuant to this Contract, and the Contractor specifically waives and assigns to the City all rights which Contractor may have under the 1990 Visual Artists Rights Act, federal, and state law, as now written or later amended or provided. In the event any products, items writings, designs, models, examples, or other work product produced pursuant to this Contract is deemed by a court of competent jurisdiction not to be a work for hire under federal copyright laws, this intellectual property rights provision shall act as an irrevocable assignment to the City by the Contractor of any and all copyrights, trademark rights, or patent rights in the Contractor's products,

items writings, designs, models, examples, or other work product produced pursuant to this Contract, including all rights in perpetuity. Under this irrevocable assignment, the Contractor hereby assigns to the City the sole and exclusive right, title, and interest in and to the Contractor's products, items writings, designs, models, examples, or other work product produced pursuant to this Contract, without further consideration, and agrees to assist the City in registering and from time to time enforcing all copyrights and other rights and protections relating to the Contractor's products, items writings, designs, models, examples, or other work product in any and all countries. It is the Contractor's specific intent to assign all right, title, and interest whatsoever in any and all copyright rights in the Contractor's products, items writings, designs, models, examples, or other work product produced pursuant to this Contract, in any media and for any purpose, including all rights of renewal and extension, to the City. To that end, the Contractor agrees to execute and deliver all necessary documents requested by the City in connection therewith and appoints the City as Contractor's agent and attorney-in-fact to act for and in Contractor's behalf and stead to execute, register, and file any such applications, and to do all other lawfully permitted acts to further the registration, prosecution, issuance, renewals, and extensions of copyrights or other protections with the same legal force and effect as if executed by the Contractor; further, the parties expressly agree that the provisions of this intellectual property rights section shall be binding upon the parties and their heirs, legal representatives, successors, and assigns.

21. WAIVERS

No waiver of default by the City of any of the terms, covenants, and conditions hereof to be performed, kept, and observed by the Contractor shall be construed, or shall operate, as a waiver of any subsequent default of any of the terms, covenants, or conditions herein contained to be performed, kept, and observed by the Contractor.

22. THIRD PARTIES

It is expressly understood and agreed that enforcement of the terms and conditions of this Contract, and all rights of action relating to such enforcement, shall be strictly reserved to the Parties hereto, and nothing contained in this Contract shall give or allow any such claim or right of action by any other or third person or entity on such Contract. It is the express intention of the Parties hereto that any person or entity, other than the Parties to this Contract, receiving services or benefits under this Contract shall be deemed to be incidental beneficiaries only.

23. TERMINATION

A. Termination for Convenience.

By signing this Contract, Contractor represents that it is a sophisticated business and enters into the Contract voluntarily, has calculated all business risks associated with this Contract, and understands and assumes all risks of being terminated for convenience, whether such risks are known or not known. Contractor agrees that the City may terminate this Contract at any time for convenience of the City, upon written notice to the Contractor. Contractor expressly agrees to and assumes the risk that the City shall not be liable for any costs or fees of whatsoever kind and nature if termination for convenience occurs before Contractor begins any work or portion of the work. Contractor further expressly agrees and assumes the risks that the City shall not be liable for any unperformed work, anticipated profits, overhead, mobilizations costs, set-up, demobilization costs, relocation costs of employees, layoffs or severance costs, administrative costs, productivity costs, losses on disposal of equipment or materials, cost associated with the

termination of subcontractors, costs associated with purchase orders or purchases, or any other costs or fees of any kind and nature, if Contractor has started or performed portions of the Contract prior to receiving notice from the City. The City shall be liable only for the portions of work Contractor actually satisfactorily completed up to the point of the issuance of the Notice of Termination for convenience. Upon receipt of this notice the Contractor shall immediately: discontinue all services affected (unless the notice directs otherwise), and deliver to the City all data, drawings, specifications, reports, estimates, summaries, and other information and materials accumulated in performing this Contract, whether completed or in process.

B. Termination for Cause: The occurrence of any one or more of the following events (“Event of Default”) will justify termination for cause:

1. Contractor’s failure to perform the work in accordance with the Contract Documents (including, but not limited to, failure to supply sufficient skilled workers or suitable materials or equipment or failure to adhere to the progress schedule as adjusted from time to time.
2. Contractor’s disregard of the laws or regulations of any public body having jurisdiction.
3. Contractor’s disregard of the authority of Project Manager.
4. Contractor’s violation in any material provision of the Contract Documents.
5. Contractor’s failure to make prompt payments to its subcontractors, and suppliers of any tier, or laborers or any person working on the work by, through, or under the Contractor or any of them, any all of their employees, officers, servants, members, and agents.
6. Contractor files a petition commencing a voluntary case under the U.S. Bankruptcy Code, or for liquidation, reorganization, or an arrangement pursuant to any other U.S. or state bankruptcy Laws, or shall be adjudicated a debtor or be declared bankrupt or insolvent under the U.S. Bankruptcy Code, or any other federal or state laws relating to bankruptcy, insolvency, winding-up, or adjustment of debts, or makes a general assignment for the benefit of creditors, or admits in writing its inability to pay its debts generally as they become due, or if a petition commencing an involuntary case under the U.S. Bankruptcy Code or an answer proposing the adjudication of Contractor as a debtor or bankrupt or proposing its liquidation or reorganization pursuant to the Bankruptcy Code or any other U.S. federal or state bankruptcy laws is filed in any court and Contractor consents to or acquiesces in the filing of that pleading or the petition or answer is not discharged or denied within sixty (60) Calendar Days after it is filed.
7. A custodian, receiver, trustee or liquidator of Contractor, all or substantially all of the assets or business of Contractor, or of Contractor’s interest in the Work or the Contract, is appointed in any proceeding brought against Contractor and not discharged within sixty (60) Calendar Days after that appointment, or if Contractor shall consent to or acquiesces in that appointment.
8. Contractor fails to commence correction of defective work or fails to correct defective work within a reasonable period of time after written notice.

If one or more of the events identified in Paragraphs 1-8 above occur, City may give Contractor written notice of the event and direct the event be cured. Any such Notice to Cure will provide Contractor a minimum of ten (10) calendar days to prepare and submit to the Project Manager a plan to correct the Event of Default. If such plan to correct the Event of Default is not submitted to the Project Manager within ten (10) days after the date of the written notice or such plan is unacceptable to the City, the City may, give Contractor (and the Surety, if any) written notice that Contractor’s services are being terminated for cause. Upon delivery of the termination notice, City may terminate the services of Contractor in whole or in part, exclude Contractor from the site, and take possession of the work and of all Contractor’s tools, appliances, construction equipment, and machinery at the project site, and use the same to

the full extent they could be used by Contractor (without liability to Contractor for trespass or conversion), incorporate in the work all materials and equipment stored at the site or for which City has paid Contractor but which are stored elsewhere, and finish the work as City may deem expedient. In such case, Contractor shall not be entitled to receive any further payment until Certificate of Completion of the work. In the event City terminates this Contract for Cause and the cost of completing the work exceeds the unpaid balance of the Contract price, Contractor shall pay City for any costs of completion which exceed the Contract price when combined with all amounts previously paid to Contractor. When exercising any rights or remedies under this paragraph City shall not be required to obtain the lowest price for the work performed. Should the cost of such completion, including all proper charges, be less than the original Contract price, the amount so saved shall accrue to the City. Neither the City nor any officer, agent or employee of the City shall be in any way liable or accountable to the Contractor or the Surety for the method by which the completion of the said work, or any portion thereof, may be accomplished or for the price paid.

Where Contractor's services have been so terminated by City, the termination will not affect any rights or remedies of City against Contractor or Surety then existing or which may thereafter accrue. Any retention or payment of moneys due Contractor by City will not release Contractor from liability.

- C. Termination Notice. Upon receipt of a termination notice, whether for convenience or cause, the Contractor shall immediately: discontinue all services affected (unless the notice directs otherwise), and deliver to the City all data, drawings, specifications, reports, estimates, summaries, and other information and materials accumulated in performing this Contract, whether completed or in process.
- D. Removal of Equipment. Except as provided above, in the case of termination of this Contract before completion from any cause whatever, the Contractor, if notified to do so by the City, shall promptly remove any part or all of Contractor's equipment and supplies from the property of the City, failing which the City shall have the right to remove such equipment and supplies at the expense of the Contractor.

24. BOOKS OF ACCOUNT AND AUDITING

The Contractor shall make available to the City if requested, true and complete records, which support billing statements, reports, performance indices, and all other related documentation. The City's authorized representatives shall have access during reasonable hours to all records, which are deemed appropriate to auditing billing statements, reports, performance indices, and all other related documentation. The Contractor agrees that it will keep and preserve for at least seven years all documents related to the Contract which are routinely prepared, collected or compiled by the Contractor during the performance of this Contract.

The City's Auditor and the Auditor's authorized representatives shall have the right at any time to audit all of the related documentation. The Contractor shall make all documentation available for examination at the Auditor's request at either the Auditor's or Contractor's offices, and without expense to the City.

25. COMPLIANCE WITH IMMIGRATION REFORM AND CONTROL ACT OF 1986

Contractor certifies that Contractor has complied with the United States Immigration Reform and Control Act of 1986. All persons employed by Contractor for performance of this Contract have completed and signed Form I-9 verifying their identities and authorization for employment.

26. LABOR

The Contractor shall employ only competent and skilled workmen and foremen in the conduct of work on this Contract. The Contractor shall at all times enforce strict discipline and good order among Contractor's employees. The Project Manager shall have the authority to order the removal from the work of any person, including Contractor's or any subcontractor's employees, who refuses or neglects to observe any of the provisions of these Plans or Specifications, or who is incompetent, abusive, threatening, or disorderly in conduct and any such person shall not again be employed on the Project.

In accord with the Keep Jobs in Colorado Act, codified at sections 8-17-101, et seq., C.R.S., Colorado labor shall be employed to perform the work to the extent of not less than eighty percent (80%) of each type or class of labor in the several classifications of skilled and common labor employed on this Project et seq.; provided however, that this paragraph shall not apply if the Project receives federal funding.

In no event shall the City be responsible for overtime pay.

27. GRATUITIES

- A. This Contract may be terminated if the Mayor, the Mayor's designee, and/or the Procurement Services Manager determine, in their sole discretion, that the Contractor or any officer, employee, agent, or other representative whatsoever, of the Contractor offered or gave a gift or hospitality to a City officer, employee, agent or Contractor for the purpose of influencing any decision to grant a City contract or to obtain favorable treatment under any City contract.
- B. The terms "hospitality" and "gift" include, but are not limited to, any payment, subscription, advance, forbearance, acceptance, rendering or deposit of money, services, or anything of value given or offered, including but not limited to food, lodging, transportation, recreation or entertainment, token or award.
- C. Contract termination under this provision shall constitute a breach of contract by the Contractor, and the Contractor shall be liable to the City for all costs of reletting the contract or completion of the project. Further, if the Contractor is terminated under this provision, or violates this provision but is not terminated, the Contractor shall be subject to debarment under the City's Procurement Regulations. The rights and remedies of the City provided in this clause shall not be exclusive and are in addition to any other rights and remedies provided by law or under this Contract.

28. NON-DISCRIMINATION

- A. In accord with section 24-34-402, C.R.S., Title VII of the Civil Rights Act of 1964, Americans with Disabilities Act of 1990 as amended, all applicable federal and state laws, the Contractor will not discriminate against any employee or applicant for employment because of disability, race, creed, color, sex, sexual orientation, gender identity, gender expression, religion, age, national origin, or ancestry.

- B. The Contractor agrees to post in conspicuous places, available to employees and applicants for employment, notices to be provided setting forth the provisions of this nondiscrimination clause.
- C. The Contractor will, in all solicitations or advertisements for employees placed by or on behalf of the Contractor, state that all qualified applicants will receive consideration for employment without regard to disability, race, creed, color, sex, sexual orientation, gender identity, gender expression, religion, age, national origin, or ancestry.

29. ORDER OF PRECEDENCE

Any inconsistency in this Contract shall be resolved by giving precedence in the following order:

- A. This Contract document with its terms and conditions
- B. Specific Construction Terms and Conditions
- C. General Construction Terms and Conditions
- D. The Statement of Work
- E. Specific Specifications
- F. General Specifications
- G. Other Appendices, Attachments, Exhibits, or Schedules

30. HEADINGS

The section headings contained in this Contract are for reference purposes only and shall not affect the meaning or interpretation of this Contract.

31. DISPUTES

- A. All administrative and contractual disputes arising from or related to this Contract other than those arising under Unanticipated Circumstances provisions (in section 107.27 of Schedule B General Construction Terms and Conditions) shall be addressed in the following manner:
 - 1. If either Party disputes or disagrees with a Contract term or the other Party's interpretation of a Contract term or has any other administrative or contractual dispute not addressed in the Unanticipated Circumstances provisions, such Party shall promptly give the other Party written notice of said dispute.
 - 2. The Parties shall hold a meeting as soon as reasonably possible, but in no event later than thirty (30) calendar days from the initial written notice of the dispute, attended by persons with decision-making authority regarding the dispute, to attempt in good faith to negotiate a resolution of the dispute; provided, however, that no such meeting shall be deemed to vitiate or reduce the obligations and liabilities of the Parties or be deemed a waiver by a Party of any remedies to which such Party would otherwise be entitled unless otherwise agreed to by the Parties in writing.
 - 3. If, within thirty (30) calendar days after such meeting, the Parties have not succeeded in negotiating a resolution of the dispute, they agree to submit the dispute to non-binding mediation and to bear equally the costs of the mediation.
 - 4. The Parties will jointly appoint a mutually acceptable mediator. If they fail to do so within twenty (20) calendar days from the conclusion of the negotiation period, they shall each select a mediator. The two mediators will then appoint a third mediator who shall conduct mediation for the Parties as the sole mediator.
 - 5. The Parties agree to participate in good faith in the mediation and negotiations for a period of thirty (30) calendar days. The substantive and procedural law of the State of Colorado

shall apply to the proceedings. If the Parties are not successful in resolving the dispute through mediation, then the Parties shall be free to pursue any other remedy afforded by the laws of the State of Colorado.

6. Until final resolution of any dispute hereunder, the Contractor shall diligently proceed with the performance of this Contract as directed by the City. For purposes of this Contract, termination for convenience shall not be deemed a dispute. The City of Colorado Springs and the Contractor agree to notify each other in a timely manner of any claim, dispute, or cause of action arising from or related to this Contract, and to negotiate in good faith to resolve any such claim, dispute, or cause of action. To the extent that such negotiations fail, the City of Colorado Springs and the Contractor agree that any lawsuit or cause of action that arises from or is related to this Contract shall be filed with and litigated only by the Colorado District Court for El Paso County, CO.

32. DELIVERY

The City may cancel this Contract or any portion thereof if delivery is not made when and as specified, time being of the essence in this Contract. Contractor shall pay the City for any loss or damage sustained by the City because of failure to perform in accordance with this Contract.

33. PAYMENTS

All invoices shall be sent to the Project Manager identified in this Contract.

The City will pay the Contractor, upon submission of proper invoices, the prices stipulated in the Contract for services rendered and accepted, less any deductions provided in this Contract within 30 days (Net 30). The City will not pay late fees or interest. Any discount payment terms offered on the invoice may be taken by the City.

All payments for Construction will be made in accordance with the Payment provisions found in Schedule B – General Construction Terms and Conditions.

Each invoice must contain at least the following information:

Contract number, issued purchase order number, invoice number, invoice date, timeframe covered by invoice, type and amount of labor and materials used for that time period, dollar amount in unit price, extended price, and total value of invoice.

34. INSPECTION OF SERVICES

The Contractor is responsible for performing or having performed all inspections and tests necessary to substantiate that the services furnished under this Contract conform to Contract requirements, including any applicable technical requirements for specified manufacturers' parts. This clause takes precedence over any City inspection and testing required in the Contract's specifications, except for specialized inspections or tests specified to be performed solely by the City.

- A. Definition of "services", as used in this clause, includes services performed, workmanship, and material furnished or utilized in the performance of services.
- B. The Contractor shall provide and maintain an inspection system acceptable to the City covering the services under this Contract. Complete records of all inspection work performed

by the Contractor shall be maintained and made available to the City during Contract performance and for as long afterwards as the Contract requires.

- C. The City has the right to inspect and test all services called for by the Contract, to the extent practicable at all times and places during the term of the Contract. The City will perform inspections and tests in a manner that will not unduly delay the work.
- D. If the City performs inspections or test on the premises of the Contractor or a subcontractor, the Contractor shall furnish, and shall require subcontractors to furnish, at no increase in Contract price, all reasonable facilities and assistance for the safe and convenient performance of these duties.

35. SECURITY

The City maintains security requirements regarding access to City buildings and other City workplaces and worksites on City property. All Contractor personnel accessing City buildings, workplaces, or worksites, may be required to produce a valid, Government issued picture identification. Contractor personnel lacking such identification may not be allowed access to such sites. No costs incurred by the Contractor due to City security requirements shall be allowable or payable under this Contract.

36. TIME IS OF THE ESSENCE

In as much as the Contract concerns a needed or required service, the terms, conditions, and provisions of the Contract relating to the time of performance and completion of work are of the essence of this Contract. The Contractor shall begin work on the day specified and shall prosecute the work diligently so as to assure completion of the work within the number of calendar days or date specified, or the date to which the time for completion may have been extended.

37. EMPLOYMENT OF LABOR

The Contractor shall comply with, and defend and hold the City harmless from any violation of all laws and lawful rules and regulations, both of the State of Colorado and of the United States, relating to Workmen's Compensation, unemployment compensation, Social Security, payment for overtime, and all other expenses and conditions of employment under this Contract.

38. SALES TAX

The Contractor must have a tax-exemption certificate from the Colorado Department of Revenue for this project. The certificate does not apply to City of Colorado Springs Sales and Use Tax which shall be applicable. The tax exempt project number and the exemption certificate only applies to County, PPRTA (Pikes Peak Rural Transportation Authority), and State taxes when purchasing construction and building materials **to be incorporated into this project**.

Furthermore, the exemption **does not** include or apply to the purchase or rental of equipment, supplies or materials that **do not become a part of the completed project or structure**. Such purchases and rentals are subject to full applicable taxation.

All contracts with subcontractors must include the City of Colorado Springs Sales and Use Tax on the work covered by the Contract, and other taxes as applicable.

Note: For all equipment, materials and supplies incorporated into the work purchased from vendors or suppliers not licensed to collect City Sales Tax (i.e. out of state suppliers, etc.), City Use Tax is due and payable to the City. The Contractor shall execute and deliver, and shall cause the Contractor's subcontractors to execute and deliver to the City Sales Tax Office, ST 16 forms listing all said equipment, materials and supplies and the corresponding use tax due, along with payment for said taxes. Any outstanding taxes due may be withheld from the final payment due the Contractor and may result in suspension of Contractor from bidding on City projects.

Forms and instructions can be downloaded at <https://coloradosprings.gov/cat/government/tax-information/sales-tax>. Questions can be directed to the City Sales Tax Division at (719) 385-5903.

Our Registration Numbers are as follows:

City of Colorado Springs

Federal I.D.: 84-6000573

Federal Excise: A-138557

State Sales Tax: 98-03479

The Contractor's payment or exemption of State of Colorado, El Paso County and City Sales and Use Taxes shall be as specified herein.

39. SEVERABILITY

If any terms, conditions, or provisions of this Contract shall be held unconstitutional, illegal, or void, such finding shall not affect any other terms, conditions, or provisions of this Contract.

40. LIABILITY OF CITY EMPLOYEES

All authorized representatives of the City are acting solely as agents and representatives of the City when carrying out and exercising the power or authority granted to them under the Contract. There shall not be any liability on them either personally or as employees of the City.

41. USE OF CITY NAME OR LOGO

Except as otherwise provided in this Contract, the Contractor shall not refer to this Contract or the City of Colorado Springs in any advertising or promotions in such a manner as to state or imply that the product or service provided is endorsed or preferred by the City of Colorado Springs, its employees, or its Departments, or is considered by these entities to be superior to other products or services. Any use of the name or logo of the City of Colorado Springs in advertising or promotions must be approved in writing by the City of Colorado Springs Contracts Specialist assigned to the Contract prior to such use.

42. TRAVEL

If travel expenses are included as a line item in this Contract, all travel expenses incurred and billable by the Contractor are subject to City approval. Air travel shall be limited to the round trip "economy coach" fare. Travel from the Colorado Springs Airport is encouraged. Unless there are extenuating circumstances, the Contractor should take advantage of lower airfares by purchasing tickets more than 14 days in advance of travel. In-state travel by air must be more economical than travel by private vehicle. Use of a private vehicle may be reimbursed per mile at the current rate published by the IRS annually. Short-term parking, long-term parking or cab fare associated

with airport departure and arrival may be allowable expenses. Valet parking will not be allowed unless it is the least expensive or only option. Car rental rates may be reimbursed for car rentals no greater than the intermediate or standard classification. The City will not reimburse any other travel methods or expenses. The City will pay for lodging, meals, and miscellaneous expenses on a per diem basis only, in accordance with the current per diem rates published by the IRS annually. The City will not pay for Contractor expenses exceeding the per diem rates. Receipts for all reimbursable expenses must be provided with the Contractor's invoice.

43. ELECTRONIC SIGNATURE

This Agreement and all other documents contemplated hereunder may be executed using electronic signature with delivery via facsimile transmission, by scanning and transmission of electronic files in Portable Document Format (PDF) or other readily available file format, or by copy transmitted via email, or by other electronic means and in one or more counterparts, each of which shall be (i) an original, and all of which taken together shall constitute one and the same agreement, (ii) a valid and binding agreement and fully admissible under state and federal rules of evidence, and (iii) enforceable in accordance with its terms

44. APPENDICES

The following Appendices are made a part of this Agreement:

1. Schedule A – Price Sheet
2. Schedule B – General Construction Terms and Conditions
3. Schedule C – Special Contract Terms and Conditions
4. Schedule D – General Specifications
5. Schedule E – Special and Technical Specifications
6. Schedule F – Scope of Work
7. Exhibit 1 – Performance, Labor and Material Payment, and Maintenance Bonds
8. Exhibit 2 – Minimum Insurance Requirements

CONTRACT SIGNATURE PAGE

IN WITNESS WHEREOF, the parties have caused these presents to be executed on the day and the year first above written.

This Contract is executed in one (1) original copy.

THE CITY OF COLORADO SPRINGS, COLORADO:

SECOND PARTY:	
Corporate Name	
Signature	Date
Title	

EXHIBIT 2 – MINIMUM INSURANCE REQUIREMENTS

The following listed minimum insurance requirements shall be carried by all contractors and consultants unless otherwise specified in the City’s solicitation package, Special Provisions or Standard Specifications.

<input checked="" type="checkbox"/>	Commercial General Liability for limits not less than \$1,000,000 combined single limit with \$2,000,000 aggregate for bodily injury and property damage for each occurrence. Coverage shall include blanket contractual, broad form property damage, products and completed operations
<input checked="" type="checkbox"/>	Workers’ Compensation and Employers Liability as required by statute. Employers Liability coverage is to be carried for a minimum limit of \$100,000.
<input checked="" type="checkbox"/>	Automobile Liability covering any auto (including owned, hired, and non-owned autos) with a minimum of \$1,000,000 each accident combined single limit.
<input type="checkbox"/>	Excess Liability for limits not less than \$1,000,000 combined single limit for bodily injury and property damage for each occurrence.
<input checked="" type="checkbox"/>	Builders Risk or Installation Floater Insurance: Contractor shall purchase and maintain property insurance written on a builder’s risk “all-risk” or equivalent policy form in the amount of the initial Contract Sum, plus value of subsequent Contract Modifications and cost of materials supplied or installed by others, comprising total value for the entire Project at the site on a replacement cost basis without optional deductibles. Such property insurance shall be maintained, unless otherwise provided in the Contract Documents or otherwise agreed in writing by all persons and entities who are beneficiaries of such insurance, until final payment has been made or until no person or entity other than the Owner has an insurable interest in the property.
<input type="checkbox"/>	Professional Liability Insurance covering any damages caused by an error, omission or any negligent acts with limits of not less than \$2,000,000 per occurrence and in the aggregate. a. In the event that any professional liability insurance required by this Contract is written on a claims-made basis, Consultant warrants that any retroactive date under the policy shall precede the effective date of this Contract; and that either continuous coverage will be maintained or an extended discovery period will be exercised for a period of three (3) years beginning at the time work under this Contract is completed. Policy shall contain a waiver of subrogation against the CITY.
<input type="checkbox"/>	Pollution Legal Liability Insurance shall apply to sudden and gradual pollution conditions resulting from the escape of release of smoke, vapors, fumes, acids, alkalis, toxic chemicals, liquids, or gases, natural gas, waste materials, or other irritants, contaminants, or pollutants (including asbestos). If the coverage is written on a claims-made basis, the Contractor warrants that any retroactive date applicable to coverage under the policy precedes the effective date of this Contract; and that continuous coverage will be maintained or an extended discovery period will be exercised for a period of three (3) years beginning from the time that work under this contract is completed. Policy limits shall be no less than \$1,000,000 per loss with \$2,000,000 aggregate coverage.

<input type="checkbox"/>	<p>Technology Errors and Omissions Liability including Network Security and Privacy Liability not less than \$3,000,000 per loss with a \$3,000,000 aggregate.</p> <p>a. The policy shall provide a waiver of subrogation.</p> <p>b. The insurance shall provide coverage for liability arising from theft, dissemination and/or use of confidential information stored or transmitted in electronic form.</p> <p>c. Network Security Liability arising from the unauthorized access to, use of or tampering to gain access to your services including denial of service, unless caused by a mechanical or electrical failure</p> <p>d. Liability arising from the introduction of a computer virus into, or otherwise causing damage to, a customer's or third person's computer, computer system, network or similar computer related property and the data, software, and programs thereon.</p>
<input type="checkbox"/>	<p>Employee Crime Coverage shall include employee dishonesty, forgery or alteration and computer fraud. If Contractor is physically located on CITY premises, third party fidelity coverage extension shall apply.</p> <p>The policy shall include coverage for all directors, officers, agents and employees of the Contractor. Coverage limit will be not less than \$1,000,000 per loss.</p> <p>a. The bond or policy shall include coverage for extended theft and mysterious disappearance.</p> <p>b. The bond or policy shall not contain a condition requiring an arrest and conviction.</p>
<input type="checkbox"/>	<p>Liquor Legal Liability Insurance: If the event producer is a business that manufactures, distributes, sells, or serves alcoholic beverages, and intends to serve or sell alcoholic beverages at an event, they must also submit a Certificate of Insurance providing proof of a liquor legal liability insurance policy or properly endorsed general liability policy.</p> <p>a. If this event producer hires a vendor to serve or sell alcoholic beverages, rather than providing the alcohol themselves, they must submit a Certificate of Insurance from the vendor providing proof of a liquor legal liability insurance policy or properly endorsed general liability policy.</p> <p>b. In either case, the minimum acceptable limit of liability per claim and aggregate is \$1,000,000. This requirement applies to the business or group which serves or sells the alcohol.</p>

Except for workers' compensation and employer's liability insurance, the **City of Colorado Springs must be named as an additional insured**. Certificates of Insurance must be submitted before commencing the work and provide 30 days' notice prior to any cancellation, non-renewal, or material changes to policies required under the contract.

All coverage furnished by contractor is primary, and any insurance held by the City of Colorado Springs is excess and non-contributory.

The undersigned certifies and agrees to carry and maintain the insurance requirements indicated above throughout the contract Period of Performance.

(Name of Company)

(Signature) (Date)

EXHIBIT 3 – QUALIFICATION STATEMENT

This statement will provide information which will enable the City to evaluate the qualifications of your firm and staff with regard to the requirements of this Invitation for Bid. Please complete this form in its entirety and submit it (in the number of copies requested) along with the other required proposal documents. If a request in the Qualification Statement is contained in the Bid, indicate the section in the Bid where that information can be found.

(PRINT)

FIRM NAME: _____

ADDRESS: _____

CITY STATE ZIP: _____

AUTHORIZED REPRESENTATIVE: _____

TITLE: _____

AUTHORIZED SIGNATURE: _____

PHONE: _____ FAX: _____

E-MAIL ADDRESS: _____

1. TYPE OF BUSINESS _____

2. TYPE OF LICENSE AND LOCATION

CORPORATION INDIVIDUAL

PARTNERSHIP JOINT VENTURE

OTHER: _____

3. TYPE OF SERVICE TO BE PROVIDED FOR IFB: _____

4. NUMBER OF YEARS IN BUSINESS: _____

5. ON A SEPARATE SHEET PROVIDE A BRIEF HISTORY OF YOUR FIRM, STAFF SIZE AND EXPERIENCE. SUBMIT A RESUME FOR THE PROJECT MANAGER AND EACH KEY PERSONNEL ASSIGNED TO THIS PROJECT.

6. WHAT OTHER NAME(S) HAS YOUR COMPANY OPERATED UNDER:

7. HAVE YOU OR YOUR FIRM EVER FAILED TO COMPLETE ANY WORK AWARDED TO YOU? YES NO IF "YES", EXPLAIN:

8. HAS ANY OFFICER OR PARTNER OF YOUR ORGANIZATION EVER BEEN AN OFFICER OR PARTNER OF ANOTHER ORGANIZATION THAT FAILED TO COMPLETE A CONTRACT WITHIN THE LAST FIVE (5) YEARS? YES NO
IF "YES", EXPLAIN:

9. HAS YOUR FIRM OR ANY PARTNERS OR OFFICERS EVER BEEN INVOLVED IN ANY BANKRUPTCY ACTION? YES NO IF "YES", EXPLAIN:

10. ARE YOU PRESENTLY INVOLVED IN ANY LITIGATION WITH ANY GOVERNMENT AGENCY? YES NO IF "YES", EXPLAIN TYPE, KIND, PLAINTIFF, DEFENDANT, ETC., AND STATE THE CURRENT STATUS:

11. BANK REFERENCE: _____
ADDRESS: _____
CONTACT: _____ PHONE: _____

12. LIST THREE (3) SIMILAR PROJECTS (LOCAL OR STATE-WIDE) **FROM LAST FIVE (5) YEARS**-INCLUDE LOCATION OF PROJECT, SIZE OF PROJECT (CONTRACT AMOUNT), CONTACT NAME, ADDRESS, TELEPHONE NUMBERS
NOTE: DETAILED INFORMATION ON THESE PROJECTS MAY ALSO BE REQUESTED IN THE IFB PACKAGE.

1. Location of Project: _____
Size of Project: _____
Contract Amount: _____
Contact Name and Title: _____
Contract Address: _____
Contact telephone and FAX Numbers: _____
2. Location of Project: _____
Size of Project: _____
Contract Amount: _____
Contact Name: _____
Contract Address: _____
Contact telephone and FAX Numbers: _____
3. Location of Project: _____
Size of Project: _____
Contract Amount: _____
Contact Name: _____
Contract Address: _____
Contact telephone and FAX Numbers: _____

13. LIST **CURRENT** SIMILAR PROJECTS (LOCAL OR STATE-WIDE) UNDER CONTRACT- INCLUDE LOCATION OF PROJECT, SIZE OF PROJECT (CONTRACT AMOUNT) CONTACT NAME, ADDRESS, TELEPHONE NUMBERS.
NOTE: DETAILED INFORMATION ON THESE PROJECTS MAY ALSO BE REQUESTED IN THE IFB PACKAGE.

1. Location of Project: _____
Size of Project: _____
Contract Amount: _____
Contact Name and Title: _____
Contract Address: _____
Contact telephone and FAX Numbers: _____

2. Location of Project: _____
Size of Project: _____
Contract Amount: _____
Contact Name and Title: _____
Contact Address: _____
Contact telephone and FAX Numbers: _____

3. Location of Project: _____
Size of Project: _____
Contract Amount: _____
Contact Name and Title: _____
Contact Address: _____
Contact telephone and FAX Numbers: _____

14. LIST OF SUB-CONTRACTORS TO BE USED FOR THIS PROJECT:
(INCLUDE NAME, ADDRESS, TELEPHONE NUMBER, TYPE OF WORK)

1. Name: _____
Address: _____
Telephone Number: _____
Type of Work: _____

2. Name: _____
Address: _____
Telephone Number: _____
Type of Work: _____

3. Name: _____
Address: _____
Telephone Number: _____
Type of Work: _____

IF ADDITIONAL INFORMATION IS PROVIDED ON A SEPARATE SHEET FOR ANY OF THE ITEMS, CLEARLY SPECIFY WHERE IT CAN BE LOCATED IN YOUR BID PACKAGE.

EXHIBIT 4 – BID CERTIFICATION AND REPRESENTATIONS AND CERTIFICATIONS

Check or Mark the space after each number to indicate compliance.

1. _____ Address of Offeror’s Principal Place of Business:

Does Offeror have an established office or facility in Colorado Springs?

Yes _____ No _____

If yes, indicate address below if different than Principal Place of Business.

Colorado Springs Facility - Year established _____

Address of Colorado Springs Facility:

Percent of Work to be Performed from Principal Place of Business? _____

Percent of Work to be Performed from Colorado Springs Facility? _____

2. _____ Indicate your ability to provide a certificate of insurance evidencing the required coverage types and limits specified in Minimum Insurance Requirements Exhibit. (The certificate of insurance must reflect the City of Colorado Springs as an Additional Insured, as applicable.)

Indicate your ability to comply with the following requirements:

The City shall be added as an Additional Insured to all liability policies:

Yes _____ No _____

Your property and liability insurance company is licensed to do business in Colorado:

Yes _____ No _____

Provide the name of your property and liability insurance company here:

Name: _____

Your property and liability insurance company has an AM best rating of not less than B+ and/or VII:

Yes _____ No _____

Worker’s Compensation Insurance is carried for all employees and covers work done in Colorado:

Yes _____ No _____

3. _____ Provide one (1) copy of current financial statements (if required). Enclose financial information in a separate envelope; do not bind with the other proposal copies. If review of the information is to be restricted to the City's financial officer, it must be marked accordingly.
4. _____ Provide the completed and signed bid. (Bids must be identified as specified in this IFB document). All required Exhibits are attached.

By signing below, the Offeror certifies that no person or firm other than the Offeror or as otherwise indicated has any interest whatsoever in this offer or any Contract that may be entered into as a result of this offer and that in all respects the offer is legal and firm, submitted in good faith without collusion or fraud. The undersigned additionally declares that it has carefully examined the Bid information and the complete Solicitation prior to submitting a Bid. The Bidder's signature will be considered the Bidder's acknowledgement of understanding and ability to comply with all items in the solicitation.

Offeror has appointed _____ as the Offeror's representative and contact for all questions or clarifications in regard to this Offeror.

Telephone: (____) _____

Email: _____

The undersigned acknowledges and understands the terms, conditions, Specifications and all Requirements contained and/or referenced and are legally authorized by the Offeror to make the above statements or representations.

_____ (Name of Company)	_____ (Signature)
_____ (Address)	_____ Date
_____ (City, State and Zip)	_____ (Telephone Number)
_____ (Name typed/Printed)	_____ (Title)
_____ (E-Mail Address)	

FEDERAL TAX ID # _____

This Company Is: Corporation ___ Individual ___ Partnership ___ LLC ___

Offeror hereby acknowledges receipt of the following amendments, if applicable. Offeror agrees that it is bound by all Amendments identified herein.

AMENDMENT #1 _____ DATED: _____

AMENDMENT #2 _____ DATED: _____

AMENDMENT #3 _____ DATED: _____

Please Note: the following Representations and Certifications must be initialed by Offeror in the spaces provided and returned with this certification.

1. INSURANCE REQUIREMENTS

Offeror shall comply with all insurance requirements and will submit the Insurance Certificates prior to performance start date. If limits are different from the stated amounts, Offeror shall explain variance. Certain endorsements and “additionally insured” statements may require further clarification and specific statements on a project specific basis and should have been described in the Offeror’s Bid.

Initials for 1

2. ETHICS VIOLATIONS

- A. The Offeror shall have in place and follow reasonable procedures designed to prevent and detect possible violations described in this clause in its own operations and direct business relationships.
- B. Offeror certifies the Offeror has not violated or caused any person to violate, and shall not violate or cause any person to violate, the City’s Code of Ethics contained in Article 3, of Chapter 1 of the City Code and in the City’s Procurement Rules and Regulations
- C. When the Offeror has reasonable grounds to believe that a violation described in this clause may have occurred, the Offeror shall promptly report the possible violation to the City Contracts Specialist in writing.
- D. The Offeror must disclose with the signing of this Bid, the name of any officer, director, or agent who is also an employee of the City and any City employee who owns, directly or indirectly, an interest of ten percent (10%) or more in the Offeror’s firm or any of its branches.
- E. In addition, the Offeror must report any conflict or apparent conflict, current or discovered during the performance of the Contract, to the City Contracts Specialist.
- F. The Offeror shall not engage in providing gifts, meals or other amenities to City employees. The right of the Offeror to proceed may be terminated by written notice issued by City Contracts Specialist if Offeror offered or gave a gratuity to an officer, official, or employee of the City and intended by the gratuity to obtain a contract or favorable treatment under a contract.
- G. The Offeror shall cooperate fully with the City or any agency investigating a possible violation on behalf of the City. If any violation is determined, the Offeror will properly compensate the City.
- H. The Offeror agrees to incorporate the substance of this clause (after substituting “Contractor” for “Offeror”) in all subcontracts under this offer.

Initials for 2

3. COOPERATION WITH OTHER CONTRACTORS

Other City activities/contracts may be in progress or start during the performance of this contract. The Offeror shall coordinate the work harmoniously with the other contractors or City personnel, if applicable.

Initials for 3

4. INTERNET USE

Should the Offeror require access to City Internet resources in the performance of this requirement, a “Contractor’s Internet Use Agreement” form must be separately signed by each individual having access to the City Network. The completed Contractor’s Internet Use Agreement will be maintained with this agreement. Inappropriate use of the City Network will be grounds for immediate termination of any awarded contact.

Initials for 4

5. LITIGATION

If awarded a contract, Offeror shall notify the City within five (5) calendar days after being served with a summons, complaint, or other pleading in any matter which has been filed in any federal or state court or administrative agency. The Offeror shall deliver copies of such document(s) to the City's Procurement Services Manager. The term "litigation" includes an assignment for the benefit of creditors, and filings of bankruptcy, reorganization and/or foreclosure.

Initials for 5

6. CONTRACTOR'S REGISTRATION INFORMATION

Offeror's firm verifies and states that they are (check all that apply):

_____ Large Business (i.e. do not qualify as a small business or non-profit)

_____ Nonprofit

_____ Small Business

_____ Minority Owned Business/Small Disadvantaged Business

_____ Woman Owned Business

_____ Veteran Owned Business

_____ Service-Disabled Veteran Owned Business

_____ HUBZone Business

Note: The City accepts self-certification for these categories in accordance with Small Business Administration (SBA) standards. The SBA size standards are found on the SBA website <https://www.sba.gov/content/am-i-small-business-concern>.

_____ Initials for 6

7. CONTRACTOR PERSONNEL

- A. The Offeror shall appoint one of its key personnel as the "Authorized Representative" who shall have the power and authority to interface with the City and represent the Offeror in all administrative matters concerning this Bid and any awarded contract, including without limitation such administrative matters as correction of problems modifications, and reduction of costs.
- B. The Authorized Representative shall be the person identified in the Offeror's Bid, unless the Offeror provides written notice to the City naming another person to serve as its Authorized Representative. Communications received by the City Contracts Specialist from the Authorized Representative shall be deemed to have been received from the Offeror.

The individual, _____ (Name)

with position, _____ (Title)

Can be reached at _____

Work telephone number: _____

Home telephone number: _____
Cellular telephone number: _____
E-mail address: _____

Initials for 7

8. OFFEROR'S CERTIFICATION

The undersigned hereby affirms that:

- A. He/She is a duly authorized agent of the Offeror;
- B. He/She has read and agrees to the City's standard terms and conditions attached.
- C. The offer is presented in full compliance with the collusive prohibitions of the City of Colorado Springs. The Offeror certifies that no employee of its firm has discussed, or compared the offer with any other offeror or City employee and has not colluded with any other offeror or City employee.
- D. The Offeror certifies that it has checked all of its figures, and understands that the City will not be responsible for any errors or omissions on the part of the Offeror in preparing its Bid.
- E. By submitting an offer the Offeror certifies that it has complied and will comply with all requirements of local, state, and federal laws, and that no legal requirements have been or will be violated in making or accepting this solicitation.
- F. If awarded the contract, the Offeror agrees to execute and enter into a contract with the City, and furnish the necessary security within ten (10) days of receipt of the "Notice of Award", and to begin the work within ten (10) day from the date of the receipt of the "Notice to Proceed", and to complete the Work with the above specifications.
- G. I hereby certify that I am submitting the Bid based on my company's capabilities to provide quality products and/or services on time.

Initials for 8

9. OFFEROR CERTIFICATION REGARDING DEBARMENT, SUSPENSION, PROPOSED DEBARMENT, AND OTHER RESPONSIBILITY MATTERS:

- A. The Offeror certifies to the best of its knowledge and belief, that (i) the Offeror and/or any of its Principals
 - 1. Are (), Are not () presently debarred, suspended, proposed for debarment, or declared ineligible for the award of contracts by any Federal agency;
 - 2. Have (), Have not (), within a three year period preceding this offer, been convicted of or had a civil judgment rendered against them for: commission of fraud or a criminal offense in connection with obtaining, attempting to obtain, or performing a public (federal, state, local) contract or subcontract; violation of Federal or state antitrust statutes relation to the submission of offers; or commission of embezzlement, theft, forgery, bribery, falsification or destruction of records, making false statement, tax evasion, or receiving stolen property; and
 - 3. Are (), Are not () presently indicated for, or otherwise criminally or civilly charged by a governmental entity with, commission of any of the offenses enumerated in any paragraphs above.
- B. The Offeror shall provide immediate written notice to the City Contracts Specialist if, at any time prior to contract award, the Offeror learns that its certification was erroneous when submitted or has become erroneous by reasons of changed circumstances.
- C. The certification in paragraph 1. above, is a material representation of fact upon which reliance was placed when making award. If it is later determined that the Offeror knowingly rendered an erroneous certification, in addition to other remedies available to the City, the City Contracts Specialist may terminate the contract resulting from this solicitation for default. Termination for default may result in additional charges being levied for the costs incurred by the City to initiate activities to replace the awarded Contractor.

Initials for 9

10. ACCEPTANCE OF CITY CONTRACTS SPECIALIST'S SOLE AUTHORITY FOR CHANGES

Unless otherwise specified in the Contract, the Offeror hereby agrees that any changes to the scope of work, subsequent to the original contract signing, shall be generated in writing and an approval signature shall be obtained from the City Contracts Specialist prior to additional work performance.

Initials for 10

11. CITY CONTRACTOR SAFETY PROGRAM

The Offeror hereby agrees to adhere to a worker safety program for contractor employees on a City job site or location. By initialing below, the Offeror has reviewed the information and will abide by the City Policy which is available for review:

<https://coloradosprings.gov/finance/page/procurement-regulations-and-documents>

Initials for 11

12. ACCEPTANCE OF CITY ENVIRONMENTALLY PREFERRED PURCHASING (EPP) POLICY

The City of Colorado Springs is committed to buying more environmentally preferable goods and services, as long as they meet performance needs, are available within a reasonable time and at a reasonable cost. The Offeror hereby acknowledges review of this policy by initialing below.

<https://coloradosprings.gov/finance/page/procurement-regulations-and-documents>

Initials for 12

13. FRAUD, WASTE, AND ABUSE

Everyone has a duty to report any suspected unlawful act impacting the City of Colorado Springs operations and its enterprises. Anyone who becomes aware of the existence or apparent existence of fraud, waste, and abuse in City of Colorado Springs is encouraged to report such matters to the City Auditor's Office in writing or on the telephone hotline 385-2387 (ADTR). Written correspondence can be mailed to:

City Auditor
P.O. Box 2241
Colorado Springs CO 80901

Or via email FraudHotline@coloradosprings.gov. Any of these mechanisms allow for anonymous reporting. For more information, please go to the website <https://coloradosprings.gov/cityfraud>.

Initials for 13

Name of Company: _____

Federal Tax ID Number: _____

DUNS Number: _____

Principal Place of Business: _____

Signature of Authorized Representative

Printed Name: _____

Title: _____

Date: _____

EXHIBIT 5 – CITY OF COLORADO SPRINGS BID BOND

1. KNOW ALL MEN BY THESE PRESENTS, THAT:

 (Name) _____ As Principal, hereinafter called Principal, and
 (Address) _____

 (SURETY Name) _____ a corporation organized and existing under
 the laws of the State of:

 (SURETY Address)
 and AUTHORIZED TO DO BUSINESS IN THE STATE OF COLORADO, as Surety, hereinafter called Surety, are held firmly bound to the CITY OF COLORADO SPRINGS, COLORADO, as Obligee, hereinafter called the Obligee, in the sum of: (Insert Bid Amount in Words) _____ (\$ _____ DOLLARS),

lawful money of the United States of America, for payment of which sum well and truly to be made, the Principal and the Surety bind themselves, their heirs, executors, successors and assigns, jointly and severally, firmly by these presents.

2. WHEREAS, the Principal has submitted to the Obligee,
 a contract bid dated the _____ day of _____ For the following contract:

3. NOW THEREFORE, THE CONDITION OF THIS OBLIGATION IS SUCH THAT, If Principals bid is accepted by Obligee and Principal is awarded the contract in whole or in part, and the Principal shall enter into the contract with the Obligee in accordance with the terms of such bid, and give such Payment, Performance, and Maintenance bond or bonds as may be specified in the bidding or contract documents with good and sufficient surety for the faithful performance of such Contract and for the prompt payment of labor and material furnished in the prosecution thereof, or in the event of the failure of the Principal to enter such contract and give such bond or bonds, if the Principal shall promptly pay to the Obligee the amount of this bond as set forth herein above, then this obligation shall be null and void, otherwise this obligation to remain in full force and effect.

Signed and sealed on the dates set forth below:

 (Witness) FOR: _____
 (Principals Name)

BY: _____
 ITS: _____
 (Seal) This _____ day of _____

 (Witness) FOR: _____
 (Surety's Name)

BY: _____
 ITS: _____
 (Seal) This _____ Day of _____

Bond # _____ This Bond (is) ___ (is not) a SBA Guaranteed Bond.